

Datainsamling

Datafångst av geografiska data

Thomas Gumbricht
thomas@karttur.com
www.karttur.com

Föreläsningens innehåll och syfte

Föreläsningen ger en introduktion till olika metoder att fånga data till geografiska informationssystem (GIS) med fokus på satellitbilder.

- Lite om geodesi
- Lite om fotogrammetri
- Principer för fjärranalys
- Plattformar och sensorer (NOAA/Landsat/Spot/MODIS)

Fångst av primärdata

Primär data - direkt fångst från digital signal

- Digital inmätning (geodetiskt instrument)
- GPS (Global Positioning System)
- Logger
- Satellitbilder
- Digital flygbildsfotografering
- Digital fotogrammetri (stereo bilder)

Fångst av sekundärdata

Sekundär data - fångst från analog datakälla

- Digitalisering
- Skanning
- Tabellinmatning
- Databaskoppling

Kort introduktion till geodesi

Definition

Geodesi är vetenskapen om jordens storlek och form (geometrisk geodesi) samt dess tyngdkraftsfält (fysikalisk geodesi)

En noggrann geodetisk uppmätning är grunden för all kartläggning

Kort introduktion till geodesi

Geodesi - kort historik

- c 200 f.Kr - Eratoshenes från Alexandria beräknade jordens omkrets med cirka 15 % fel, de första trigonometriska beräkningarna
- c 150 f.Kr - Hipparchos gradnät (360°) - jordens omkrets satt till 32 000 km (cirka 25 % för litet)
- 1570 - Den första teodoliten (för vinkelmätning)
- 1600 - Tycho Brahe mäter in Ven och angränsande land
- 1640 - R. Descartes lägger grunden för modern geodesi
- 1737 - J. Harrison uppfinnar den första kronometern
- 1820 - C.F. Gauss och L. Kruger utarbetar projektioner
- 1880 Nollmeridianen bestäms till Greenwich

Kort introduktion till geodesi

Maupertius
triangelnät i
Tornedalen 1736
- uprättat för att
kontrollera om
jorden var
avplattad vid
polerna som
newton
förutsagt.



Kort introduktion till geodesi

Geodetiska mätmetoder

- Avvägning (höjddata)
- Triangulering - trigonometrisk beräkning
 - Teodoloit
 - Elektromagnetisk DistansMätning (EDM) (laser)
 - Rymdtriangulering - mätning mot satellit (används sällan numer)
- Tröghetspositionering (acceleration-retardation)
- Satellitnavigering (NAVSTAR-GPS, Galileo), beräkning bl.a. via dopplereffekt
- VLBI (Very Long Baseline Interferometry), positionering mot astronomiska radiokällor

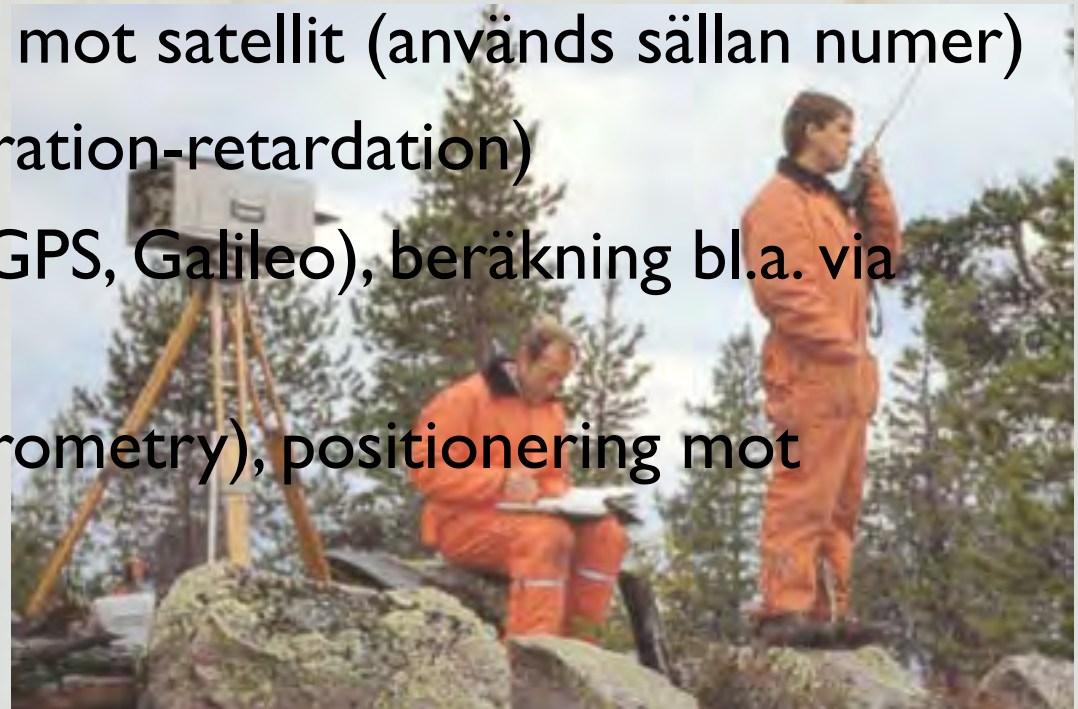
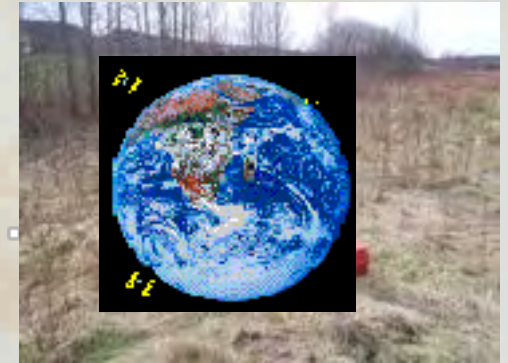

Kort introduktion till geodesi

Omloppsbanana för två av GPS-satelliterna under ett dygn

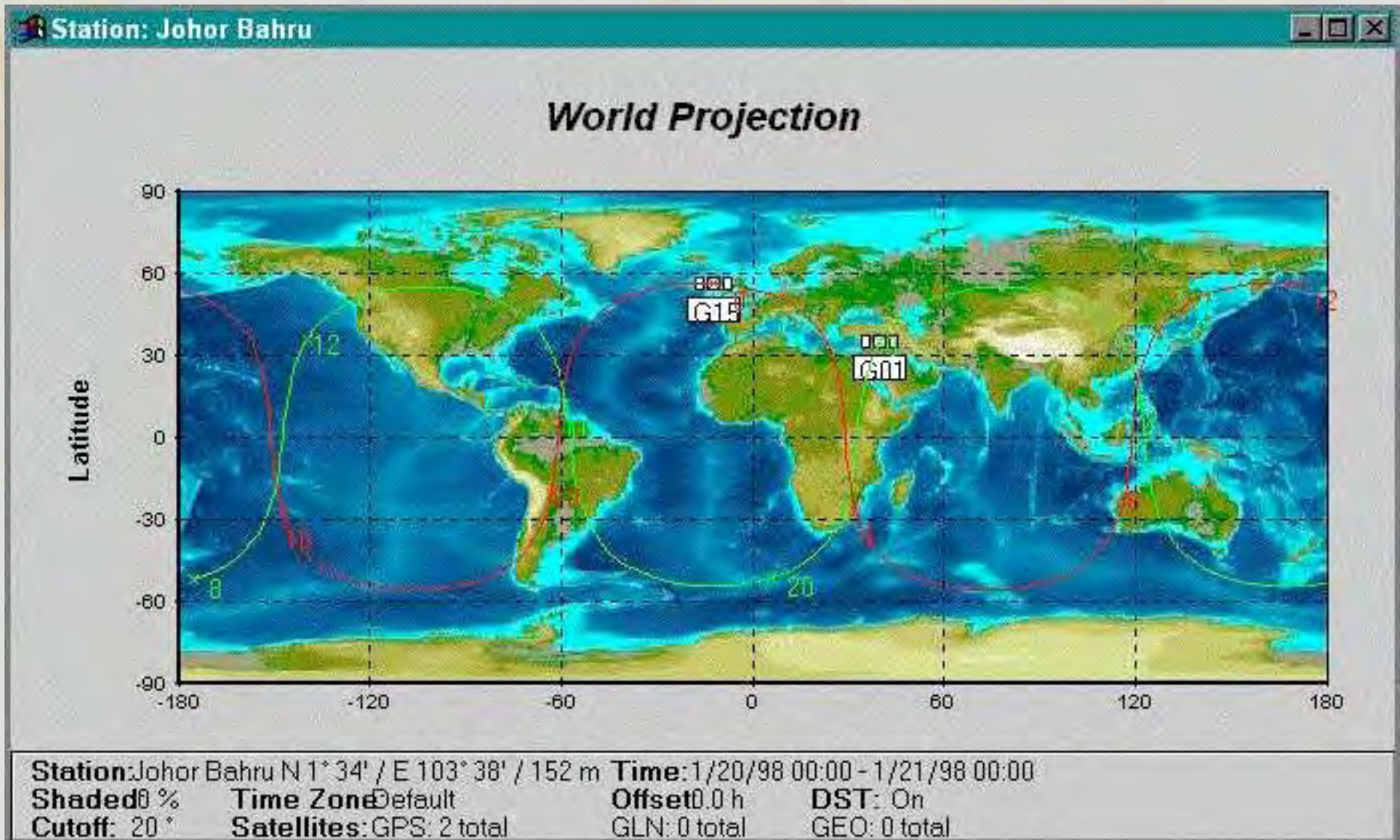

Kort introduktion till geodesi

Skillnaden mellan EDM (laser) och GPS

Two - way ranging (eg EDM)
one clock used to measure Δt

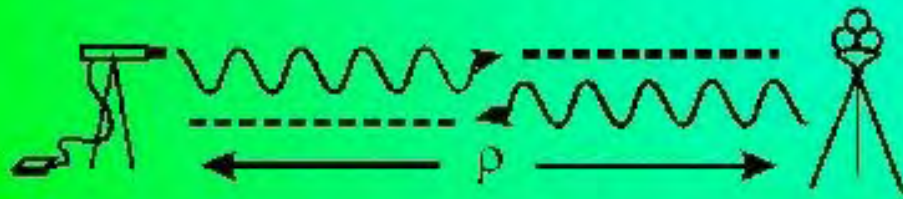

measure $\Delta t = 2\rho/c = \text{two way travel time}$
calculate $\rho = c \Delta t / 2$

GPSCD

Med laser (och radar) mäter man
distans mot två vägar och en klocka

One - Way Ranging (eg GPS)

T_x clock generates signal
 R_x clock detects signal arrival
the two clocks must keep same time!

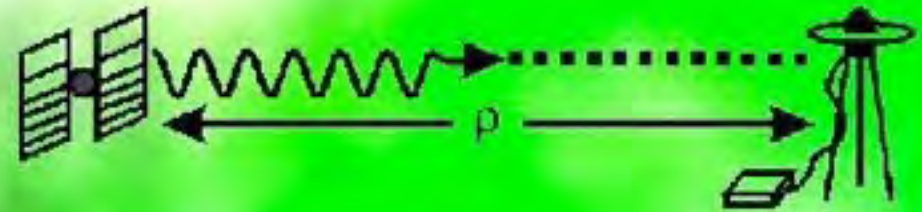

measure $\Delta t = \rho/c = \text{one way travel time}$
calculate $\rho = c \Delta t$

GPSCD

Med GPS mäter man distans mot en
väg och två klockor

Fotogrammetri

Definition

Fotogrammetri är vetenskapen om att göra mätningar av tre-dimensionella positioner hos objekt i världen utifrån två eller flera fotografiska eller digitala bilder

Till de vanligaste tillämpningarna hör topografisk kartering, skogsinventering och militära ändamål.

Detaljerad fotogrammetri används även inom arkitektur, arkeologi, medicin mm.

Fotogrammetri och fjärranalys

Kort historik om fotogrammetri och flygbilder I

- c 330 f.Kr - Aristoteles filosoferar om ljusets egenskaper
- c 1000 - Al Hazen förklarar principerna för kamera obscura
- 1267 - Roger Bacon konstruerar en kamera obscura för att skapa optiska illusioner
- 1490 - Leonardo da Vinci beskriver i detalj funktionerna för camera obscura
- 1572 - Friedrich Risnor använder camera obscura principen för topografisk kartering
- 1614 - Angelo Sala upptäcker att salter av silver är ljuskänsliga
- 1666 - Sir Isaac Newton upptäcker att ett prisma kan bryta och separera ljus av olika våglängder
- 1676 - Johann Christopher Sturm använder speglar för att konstruera en lins
- 1777 - Carl Wilhelm Scheele upptäcker att silversalter kan fixeras efter ljusexponering
- 1802 - Thomas Young lägger fram en teori för färgseende baserat på separata receptorer för rött - grönt - blått

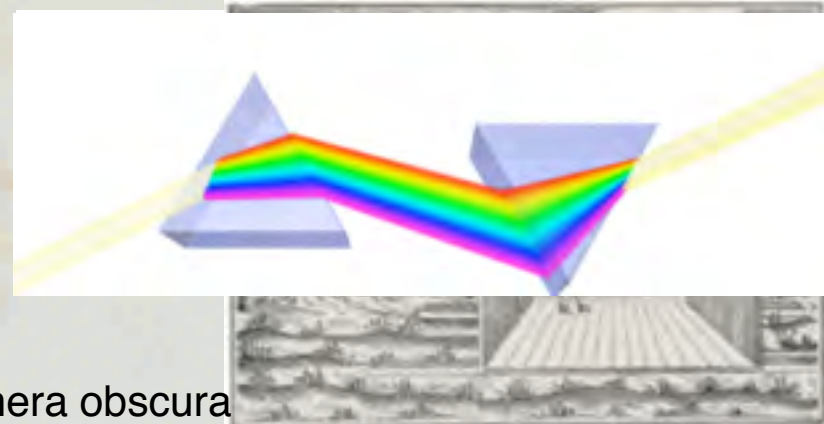

Fotogrammetri och fjärranalys

Kort historik om fotogrammetri och flygbilder 2

- 1827 - Joseph Nicephore Niepce tar det första fotografier i Frankrike (exponeringstiden var 8 timmar)
- 1830 - Stereoskopet upptrinns
- 1830-1850 Utveckling av olika ljuskänsliga emulsioner
- 1858 - Gaspar Felix Tournachon tar det första flygfotografiet från en ballong över
- 1860 - Flygfotografering från ballonger börjar användas för kartering
- 1861 - Thomas Sutton skapar det första färgfotografiet med hjälp av James Clark Maxwell, de använder fyra färgfiler (rött, grönt, blått och gult)
- 1873 - Herman Vogel upptäcker infraröd känslig emulsion
- 1887 - Kartläggning av skogar från flygbilder börjar i Tyskland
- 1903 - Brevduvor börjar användas för flygfotografering i Tyskland
- 1907 - De två franska bröderna Auguste och Louis Lumiere utvecklar ett system för färgfotografering och skapar 35 mm formatet.
- 1909 Wilbur Wright tar de första flygfotografierna.



Världens äldsta bevarade flygfoto
Boston, 1860 - James Wallace Black

Fotogrammetri och fjärranalys

Kort historik om fotogrammetri och flygbilder 3

- 1914-1918 - Under första världskriget utvecklas speciella kameror för flygfotografering, särskilt Franska armén använder sig i stor utsträckning av flygbilder.
- 1918-1939 Under mellankrigstiden utvecklas nya emulsioner och flygfotografier vinner inträde i många civila tillämpningar
- 1939-1945 Flygbildsteknik och tillämpningar utvecklas för militära ändamål, först i Tyskland och sedan hos de allierade. Landningsplatser för fartyg och terrängens framkomlighet kartläggs från flygbilder.
- 1946 - Första satellitbilden över jorden tas med en V2 raket
- 1950 - Utveckling av multispektrala sensorer
- 1954 - Spionflygplanet U2 lyfter för första gången (fortfarande i tjänst)
- 1957 - Sovjet skjuter upp Sputnik.
- 1960 - Tiros 1, den första vädersatelliten sänds upp, efter TIROS 10 utvecklas och skjuts fortfarande upp satelliter i denna serie.
- 1960 USA skickar upp flera generationer av spiosatelliten CORONA, den första från pol-till-pol. Bilderna släpps ned till marken och framkallas i laboratorier
- 1972 ERTS-1, omdöpt till Landsat1 sänds upp, utrustad med två multispektrala sensorer - Return Beam Vidicon (fungerar kort tid) och MultiSpectral Scanner (MSS)

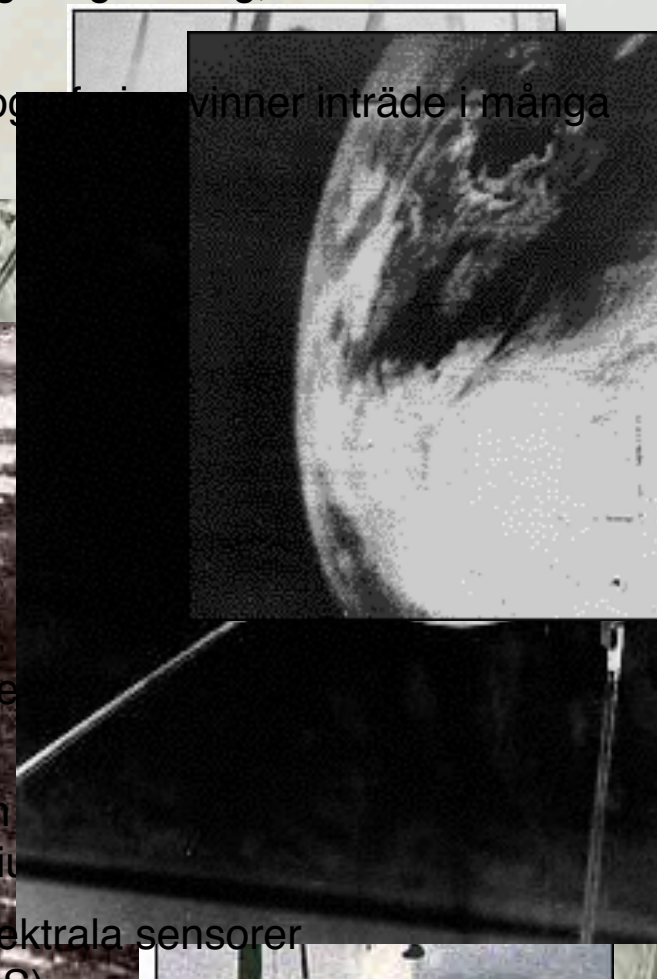

Fotogrammetri och fjärranalys

Kort historik om fotogrammetri och flygbilder 4

- 1972 - Fotografier tagna med Hasselbladskameror från Skylab används för att göra markanvändningkartor
- 1975 Landsat 2 skjuts upp. GOES 1, den första geostationära vädersatelliten skjuts upp.
- 1977 - ESA skjuter upp Meteosat-1 (geostationär).
- 1978 - USA skjuter upp Landsat 3, Seasat, den första radar satelliten Polar (fungerar i cirka 100 dagar), och Nimbus-7 (ozon-mätningar - TOMS)
- 1981 - Uppskjutning av Space-Shuttle Imaging Radar (Sir-A), Meteosat-2.
- 1984 - Uppskjutning av Landsat 4.
- 1986 - Frankrike skjuter upp SPOT-1 (Système Probation de la Observatio
- 1988 - Indien skjuter upp IRS-1A (Indian Remote Sensing).
- 1990 - Uppskjutning av SPOT-2.
- 1991 - ESA skjuter upp ERS-1 med SAR (Synthetic Aperture Radar) och altimeter som möjliggör detaljerad höjdmätning av jordytan, Uppskjutning av IRS-1B.
- 1992 Japan skjuter upp JERS-1 (SAR), USA skjuter upp den första satelliten som är byggd för att kartlägga haven - Topex/Poseidon.



Fotogrammetri och fjärranalys

Kort historik om fotogrammetri och flygbilder 5

- 1993 - Uppskjutning av SPOT-3, Landsat 6 kommer bort efter uppskjutning (aldrig återfunnen)
- 1995 - CORONA och andra tidiga spionsatellitbilder deklassifieras.
- 1995 - Orbview skjuter upp den första kommersiella satelliten (Orbview-1), uppskjutning av ERS-2 och IRS-1C, Kanada skjuter upp en SAR satellite - Radarsat-1.
- 1996 - Indien skjuter upp IRS-P3, misslyckad uppskjutning av SPOT-3.
- 1997 - Uppskjutning av Orbview-2 med SeaWifs, Japan skjuter upp ADEOS-1, Indien IRS-1D, ESA Meteosat-7.
- 1998 - Uppskjutning av SPOT-4
- 1999 - Uppskjutning av Landsat 7, Ikonos (första civila satellit med upplösning på 1 m), ochTERRA (med fem separata instrument - MODIS, ASTER, CERES, MISR och MOPITT, vilket möjliggjort mycket bättre kalibrering av instrumenten).
- 2000 - Shuttle Radar Topography Mission - global topografisk kartläggning
- 2001 - Uppskjutning av Quickbird, kommersiell satellit med 61 cm upplösning (Google Earth´s detaljerade bilder)
- 2002 - Uppskjutning av Aqua (syster till TERRA), Envisat (ESA´s motsvarighet till TERRA och AQUA, med ännu fler instrument), SPOT-5, Meteosat Second generation (MSG), ADEOS-II.
- 2003 - Uppskjutning av ICESat, första jordobservationssatelliten med lasermätning (fungerar inte fullt ut), efterföljaren Cryosat exploderade vid uppskjutning 2005.

Fotogrammetri

Principerna för en kamera

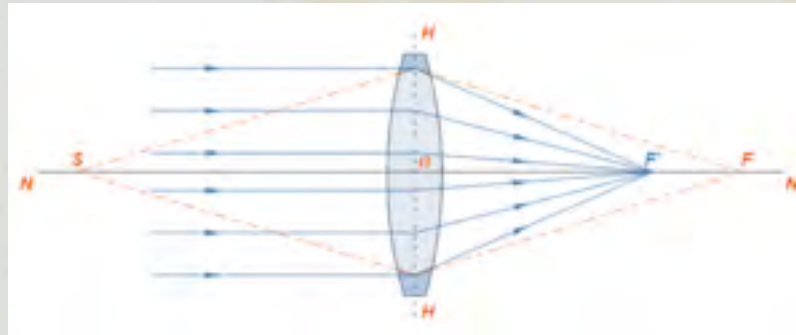

Parallellt infallande ljus (**blått**) från fjärran objekt
Fokuspunkten = brännvidd eller principalfokus

Divergent infallande ljus (**rött**) från närliggande objekt
Fokuspunkten varierer med avstånd till objektet

Scale Variation due to Topography

Two equal distances d_1 och d_2 in the object can be depicted as not equal in the image, due to the topography of the object (terrain variations).

Objects closer to the camera will be depicted in a larger scale.

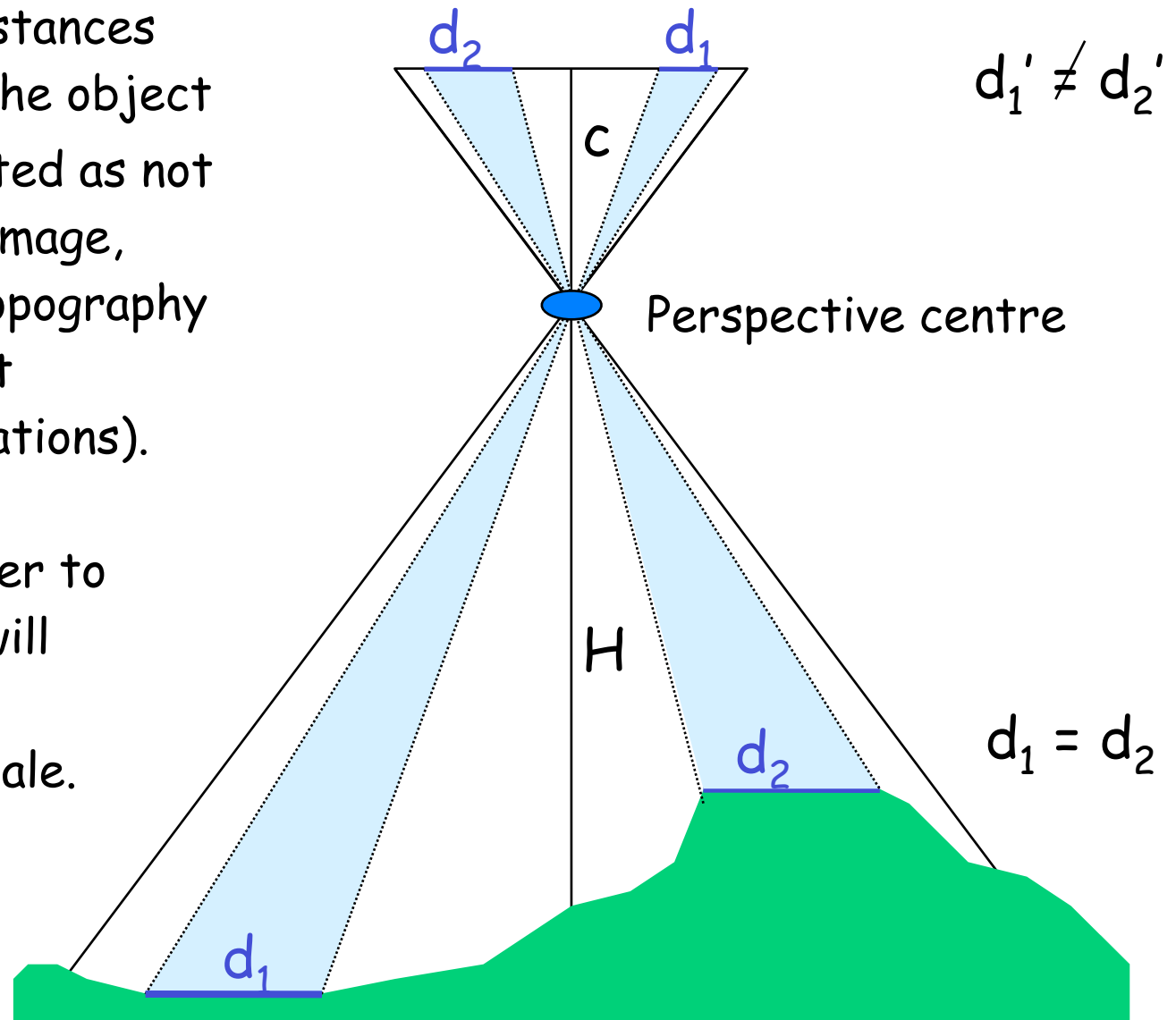

Scale Variation due to Camera Tilt

Jonas



Two equal distances d_1 och d_2 in the object can be depicted as not equal in the image, due to the tilt of the camera axis.

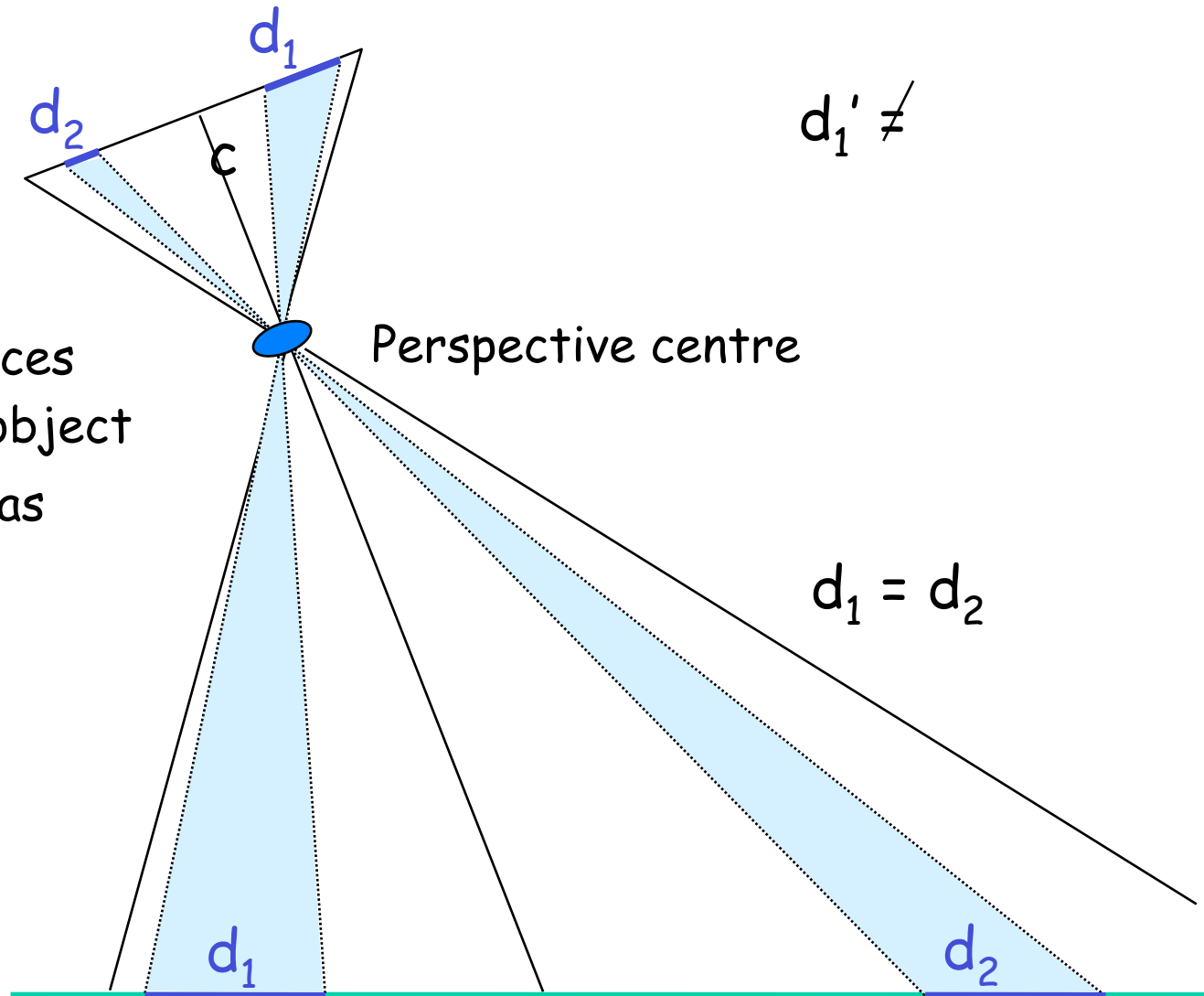

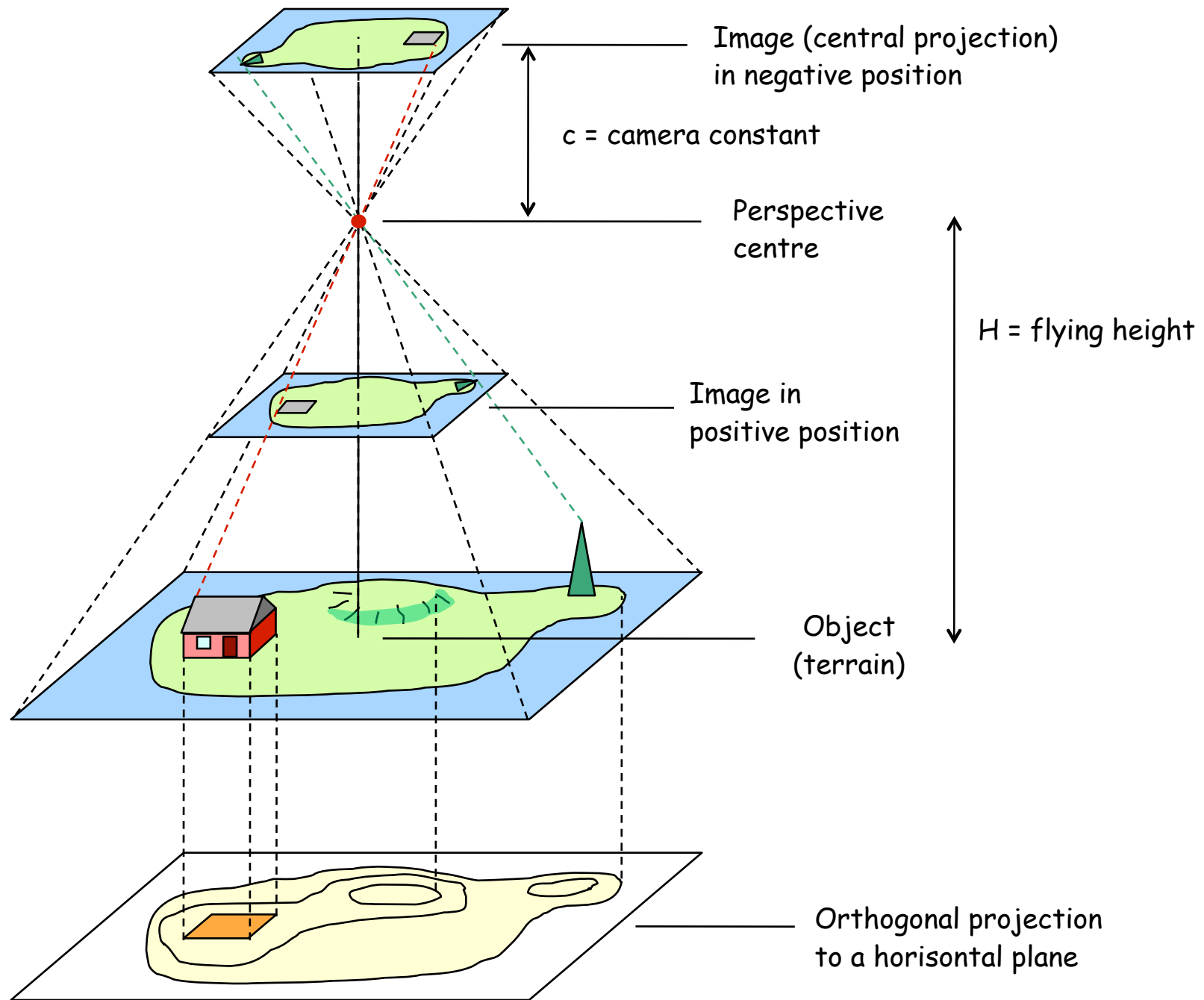

Jonas



Central Perspective

Imagine nine high-rise buildings viewed from above:

Central Projection (photo):

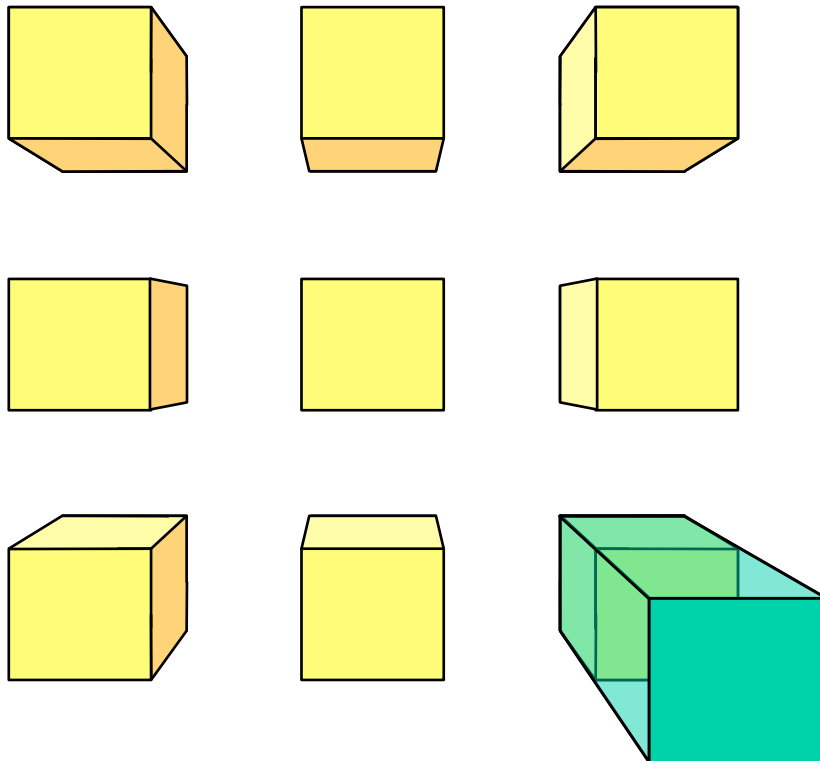

Orthogonal Projection (map):

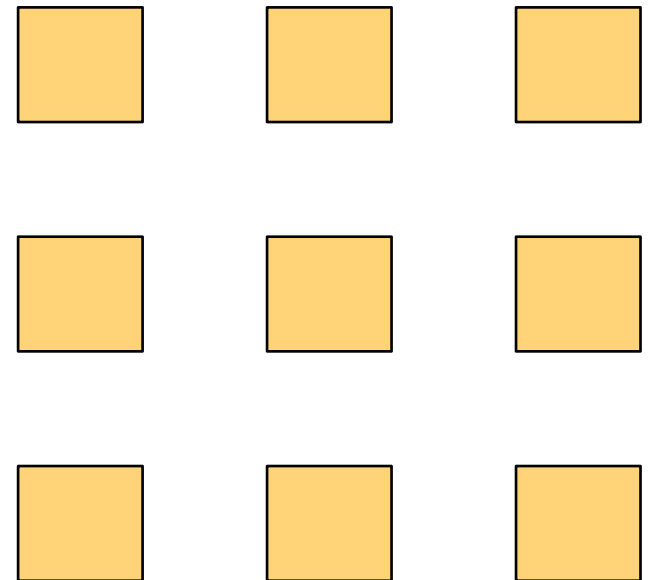

- Radial displacement
- Scale differences

Jonas



Relief Displacement

(Radial
Displacement)

Jonas



Fotogrammetri

Förutom variationer i terrängen kan förskjutningar i bilden uppstå genom att

- kameran är tiltad
- jordytans rundning.

Betydelsen av jordytans rundning är oftast negligerbar.

Fotogrammetri

Däremot är tiltning av kameran ett problem vid flygfotografering och alla annan fotografering

Tiltningen kan vara i rummets tre dimensioner: Nick (Pitch), Rotation (Yaw) och Rullning (Roll)

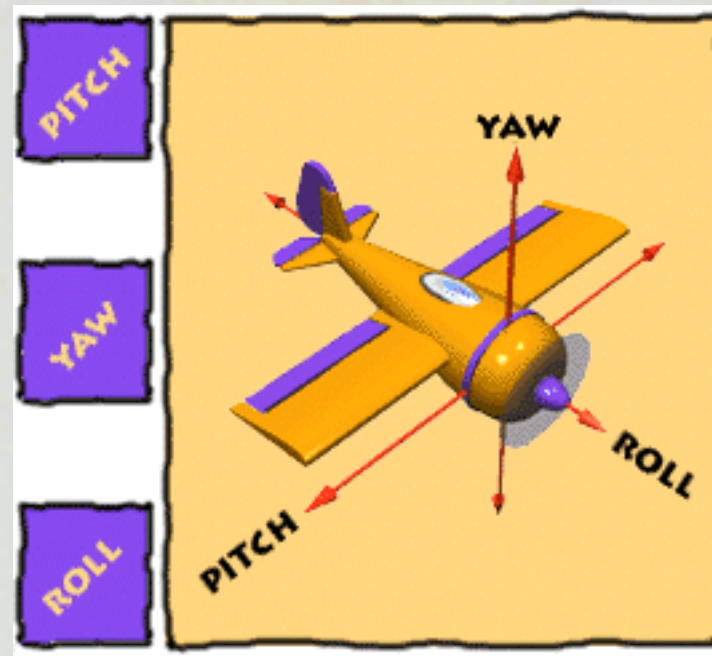

Fotogrammetri

Nick (eng: Pitch)

Tiltning runt sidoaxeln (ving-axeln) kallas Nick

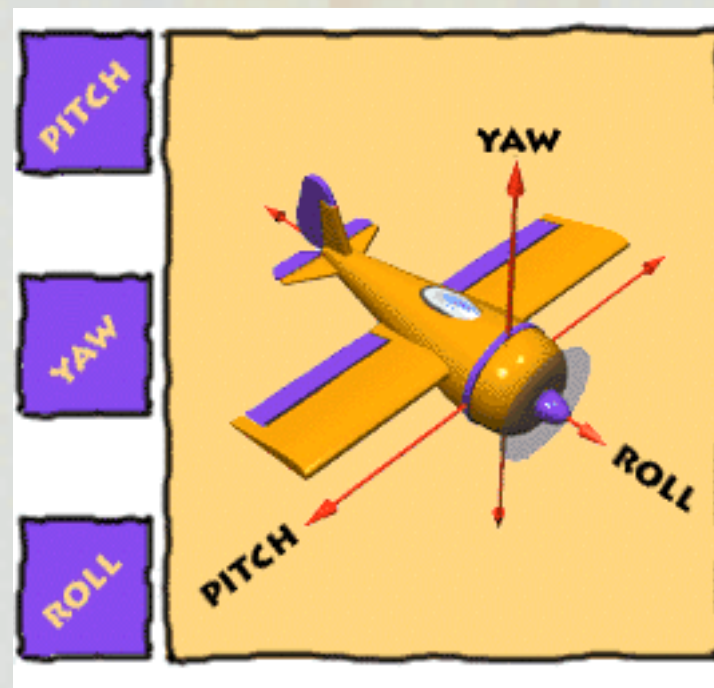

Fotogrammetri

Rotation (eng: Yaw)

Tiltning runt den vertikala axeln kallas rotation

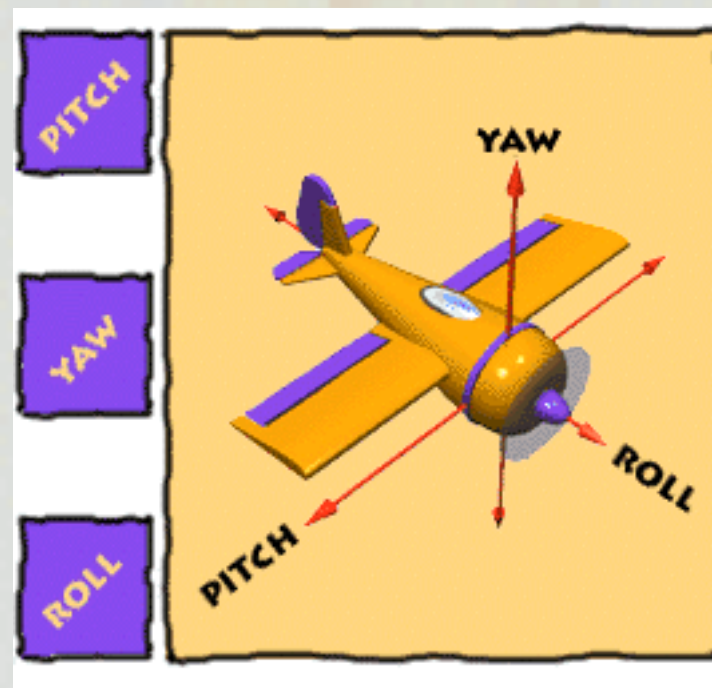

Fotogrammetri

Rullning (eng: Roll)

Tiltning runt längsaxeln kallas rullning

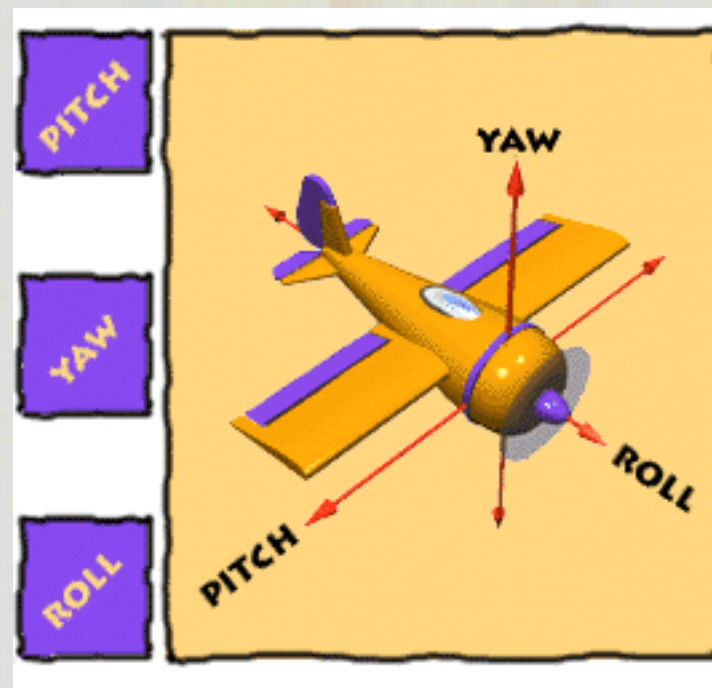

Fotogrammetri

Förutom förskjutningar påverkas en korrekt avbildning också av förvrängningar genom

- rörelser i bilden
- atmosfäriska störningar
- krympningar i material (papper, film)
- linser

Fotogrammetri

Oftast är det linsen som orsakar den största störningen

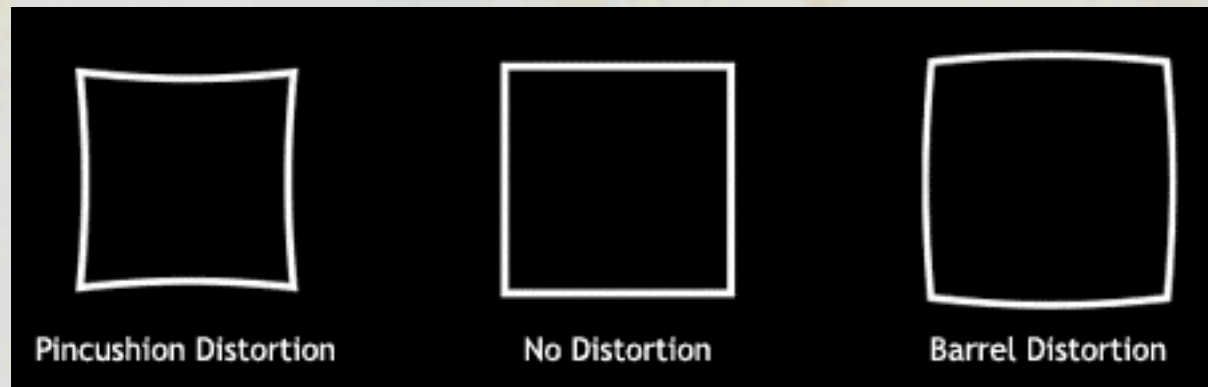

Typisk distortion hos
linser med långa brännvidder
(teleobjektiv)



Typisk distortion hos
linser med korta brännvidder
(vidvinkelobjektiv)

Fotogrammetri

Ortorektifiering

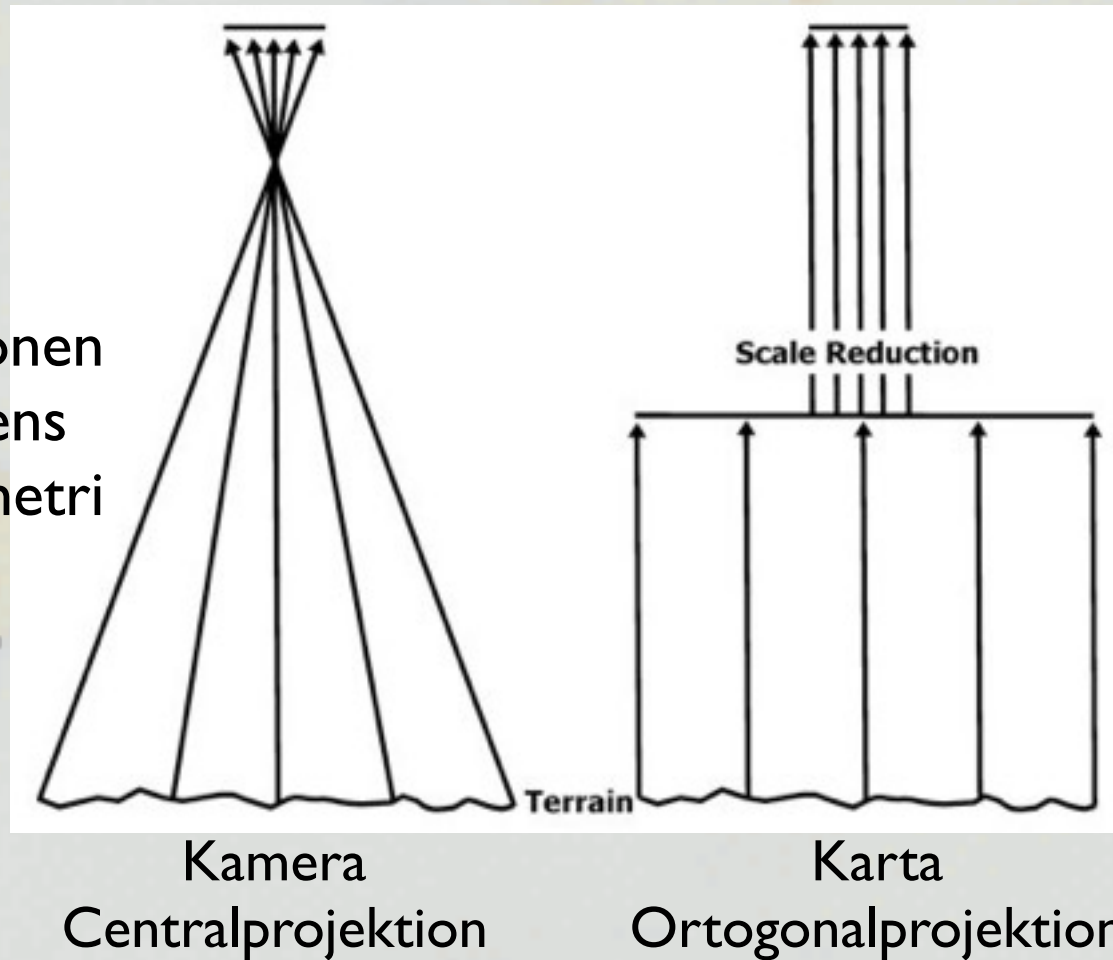

I centralprojektion
varierar objektens
storlek och geometri

En ortogonal
projektion återger
objekten både
planimteriskt och
geometriskt
korrekt

Fotogrammetri

Ortorektifiering

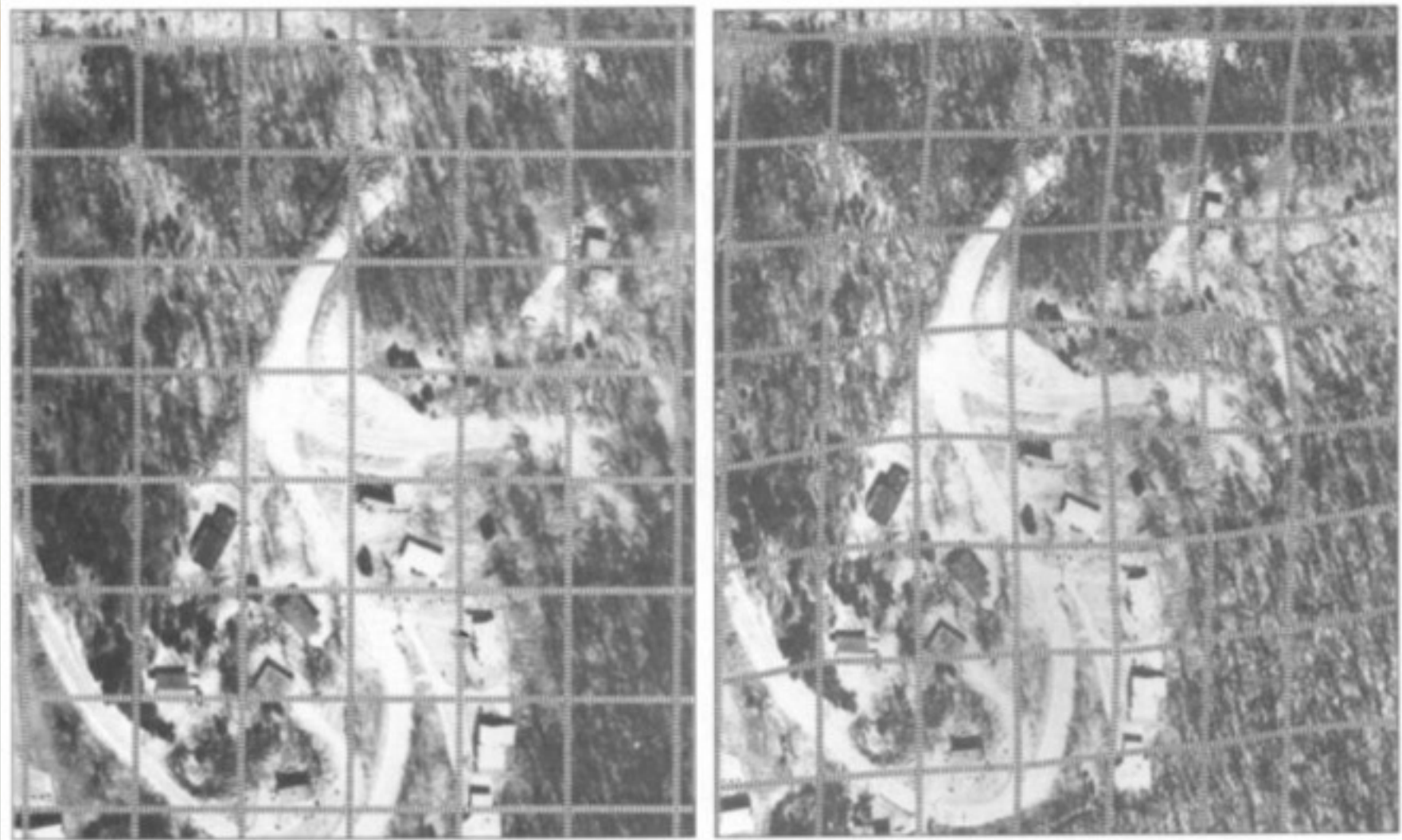

Original och ortorektifierad flygbild

Fotogrammetri



Fjärranalys

Definition

Fjärranalys är ett vetenskapsområde nära relaterat till bildanalys som avser metoder att göra mätningar av egenskaper hos omgivningen från satellitbilder och flygbilder.

Vanliga tillämpningar utgörs av väderobservationer, mätningar av vegetationsegenskaper, och miljöförroeningar.

Fjärranalys

Elektromagnetisk strålning

Alla objekt med en temperatur högre än absoluta nollpunkten (-273°C) reflekterar, absorberar och emitterar energi i form av elektromagnetisk strålning.

Våglängden på den emitterade strålningen beror primärt på temperaturen - ju högre temperatur desto kortare (intensivare) våglängd.

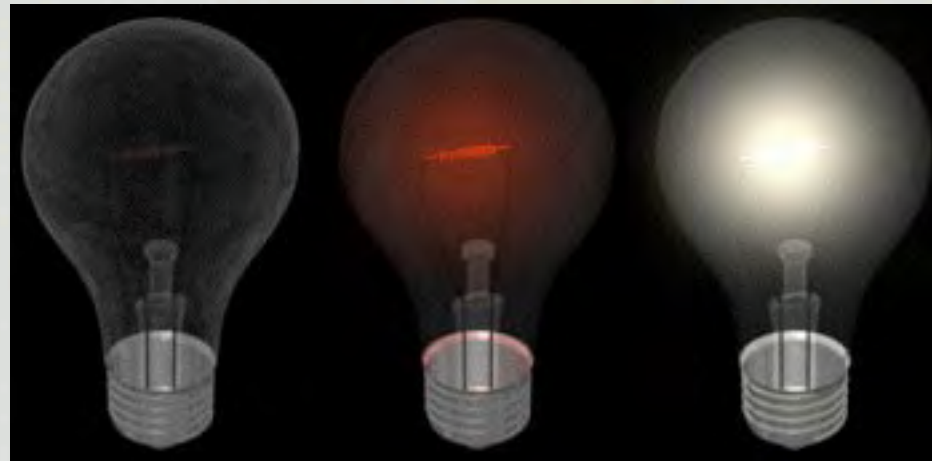

Fjärranalys

Elektromagnetisk strålning

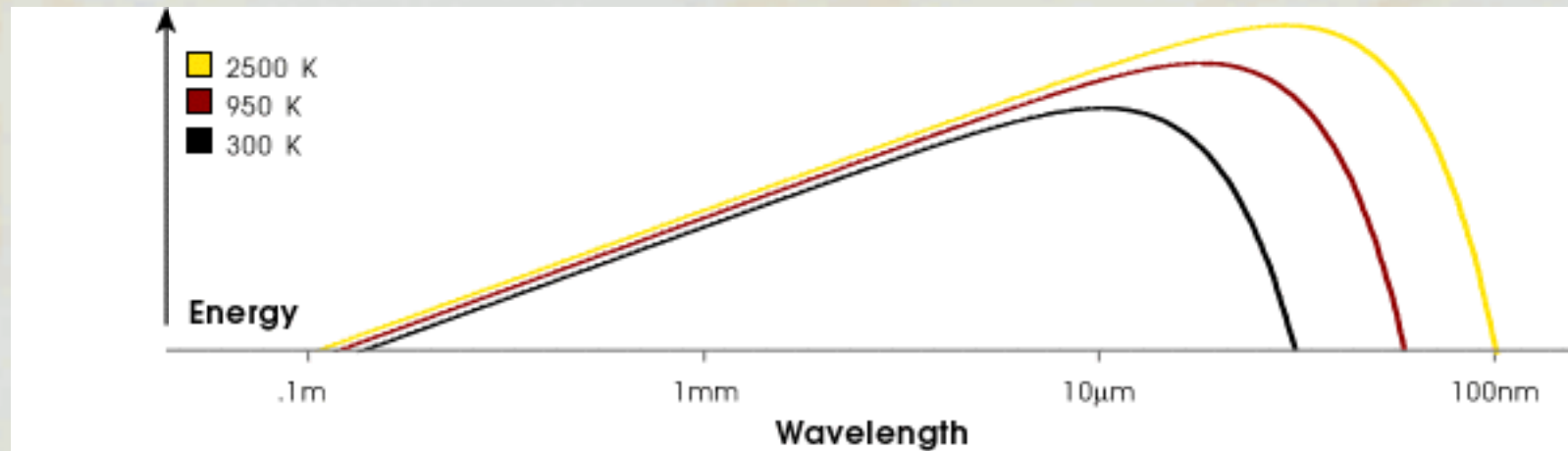

Energiinnehållet i den elektromagnetiska strålningen ökar med temperaturen. Blått ljus innehåller mer energi än rött, och synligt ljus innehåller mer energi än infrarött.

En kropp som först absorberat energi och sedan re-emitterar denna energi sänder därför ut strålning med längre våglängd jämfört med den strålning som först absorberades.

Fjärranalys

Uppdelning av det elektromagneiska spektrumet

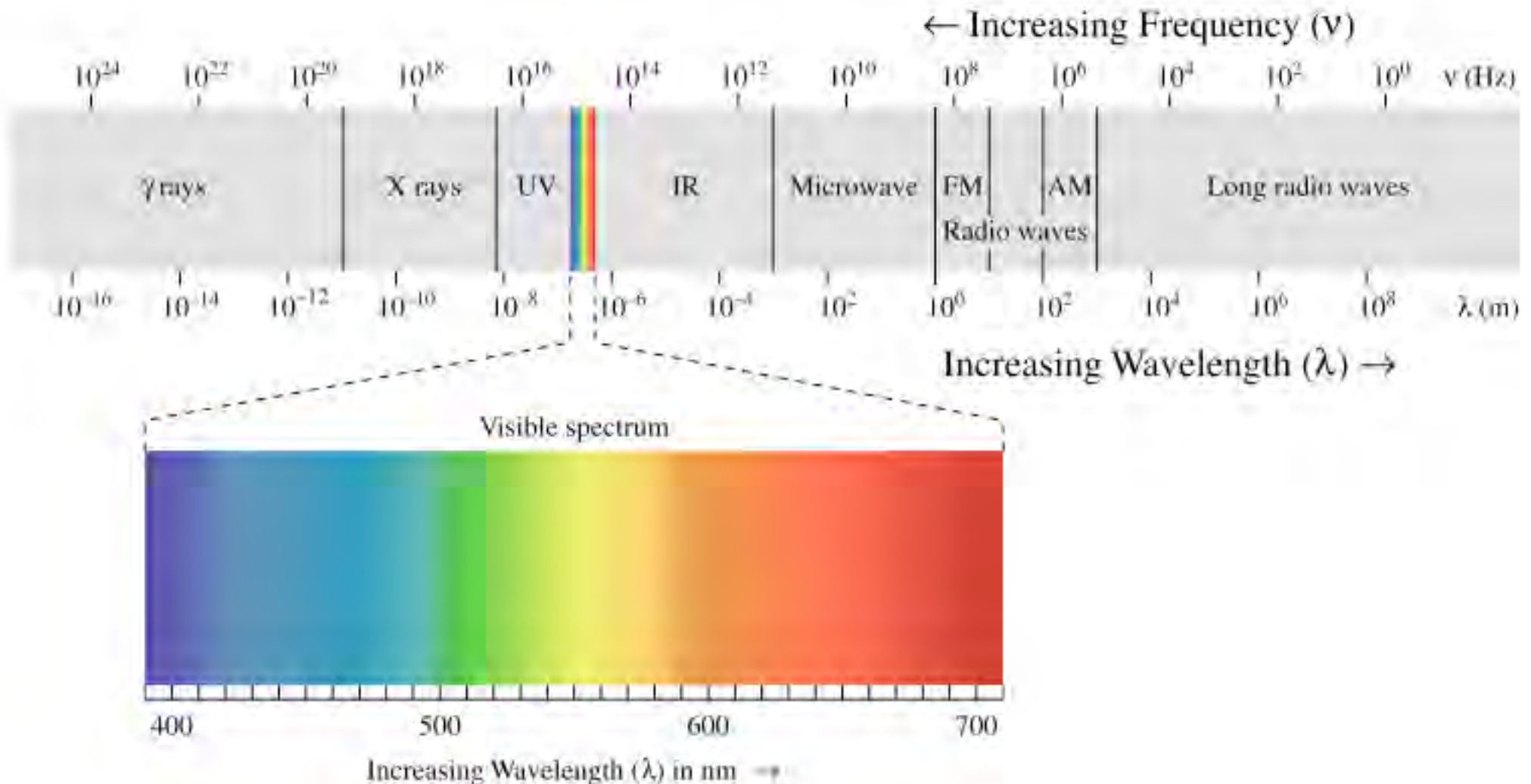

Fjärranalys

Jordatmosfärens transmissivitet för olika våglängder inom det elektormagnetiska spektrumet

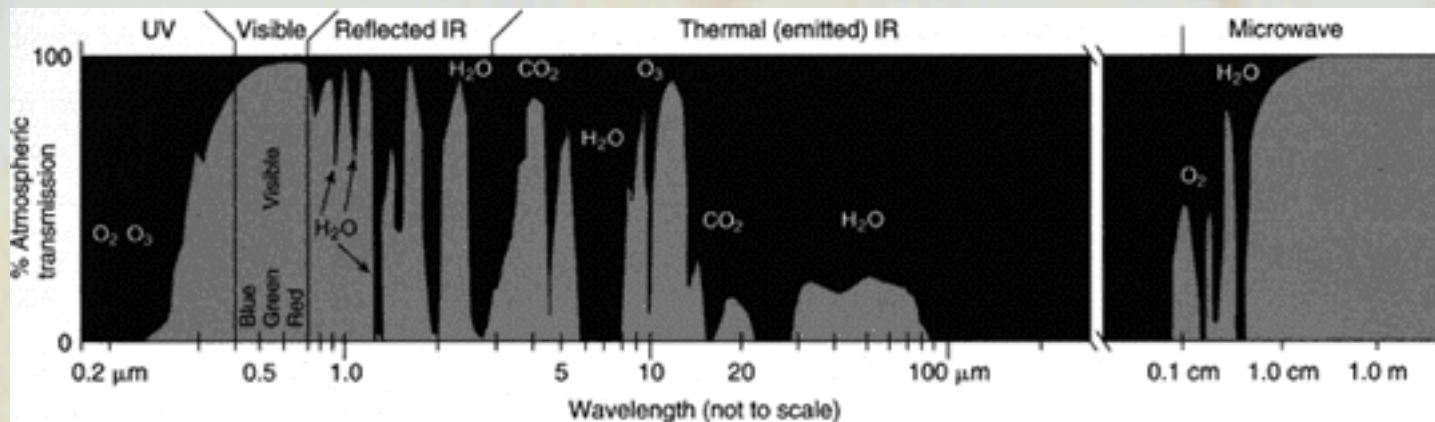

Atmosfärens gaser absorberar elektromagnetisk strålning av olika våglängder.

Fjärranalys

Metoder för att detektera elektromagnetisk strålning

- Passiva sensorer - detekterar naturlig strålning (vanligtvis reflektioner från solen)
 - Radiometer - detekterar inom ett visst våglängdsband (blått, grönt, rött, infrarött etc)
 - Imaging radiometer - en radiometer som skannar bildlinjer dimensioner och sedan bygger samman en bild
 - Spectrometer - en radiometer där det elektromagnetiska spektrumet delats upp innan det träffar sensorn (typiskt via ett prisma)
 - Spectroradiometer - en radiometer som kan mäta elektromagnetisk strålning i flera, ofta väl definierade våglängder simultant (multispektral radiometer)

Fjärranalys

Metoder för att detektera elektromagnetisk strålning

- Aktiva sensorer - sänder ut egen strålning och registreras reflektionen av denna
 - Radar - (Radio Detection and Ranging) emitterar radio eller mikrovågsfrekvenser genom en riktad antenn och mäter den returnerade reflektionen. Avståndet till objektet kan beräknas från tiden det tar mellan emission och registrering.
 - Scatterometer - hög frekvent mikrovågsradar, kan användas för att mäta vindar över vattenytan.
 - Lidar (Light Detection and Ranging) - emitterar ljuspulser och mäter reflekterat ljus som träffar sensorn. Förutom avstånd kan Lidar nyttjas för att mäta atmosfärens komposition.

Spectral Reflectance

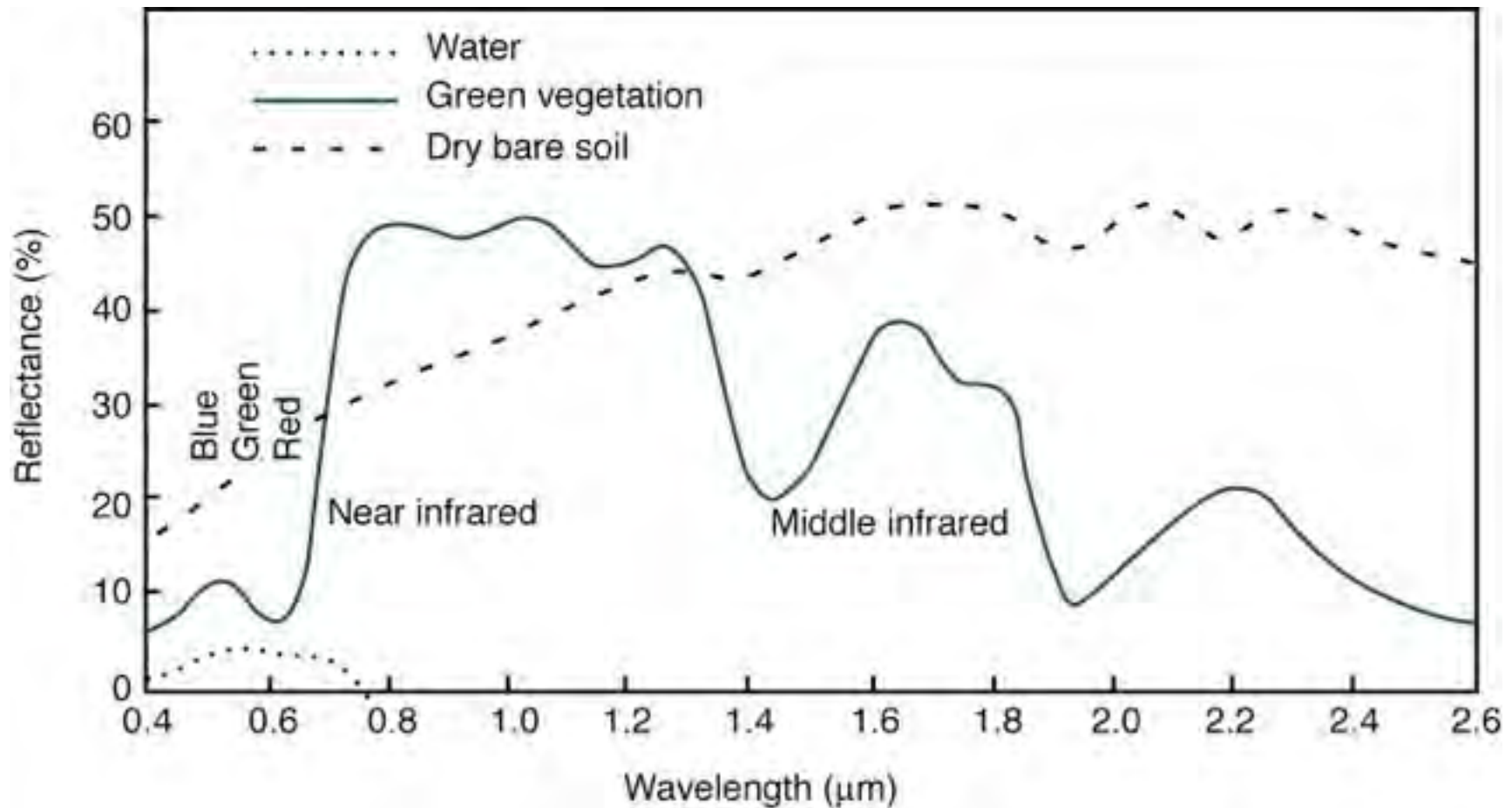

Different object classes has different spectral reflections
- but beware; two objects belonging to the same object class
may also have different spectral reflections!

Resolution

Spatial resolution

Refers to the size of the object that can be resolved.

Spectral resolution

Refers to the part of the electromagnetic spectrum being measured.

Temporal resolution

Refers to the frequency (repeat cycle) with which images can be collected for the same area.

Airborne sensor application segments

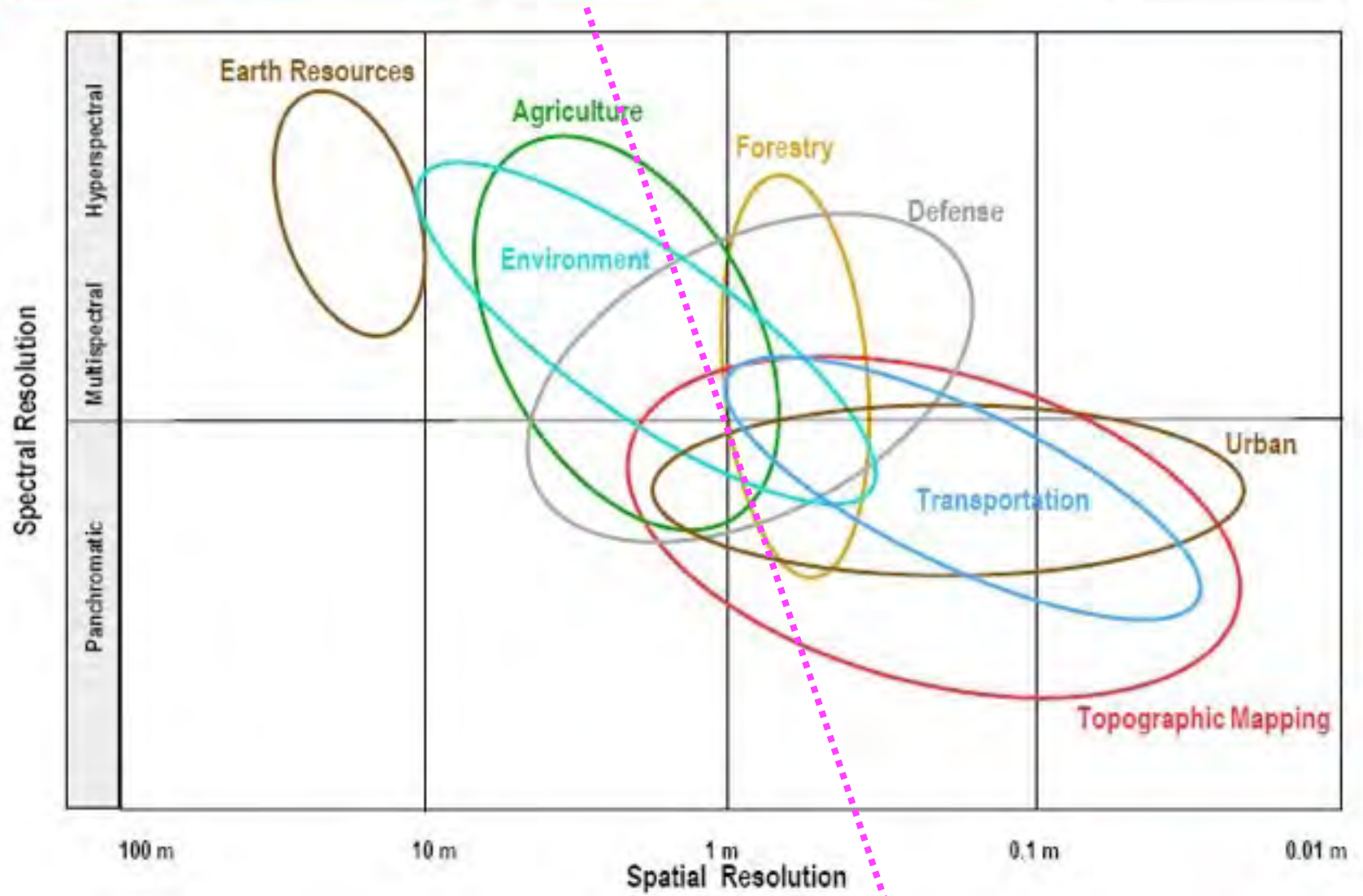

← Satellite sensors Airborne sensors

Jonas



Airborne and Spaceborne imagery

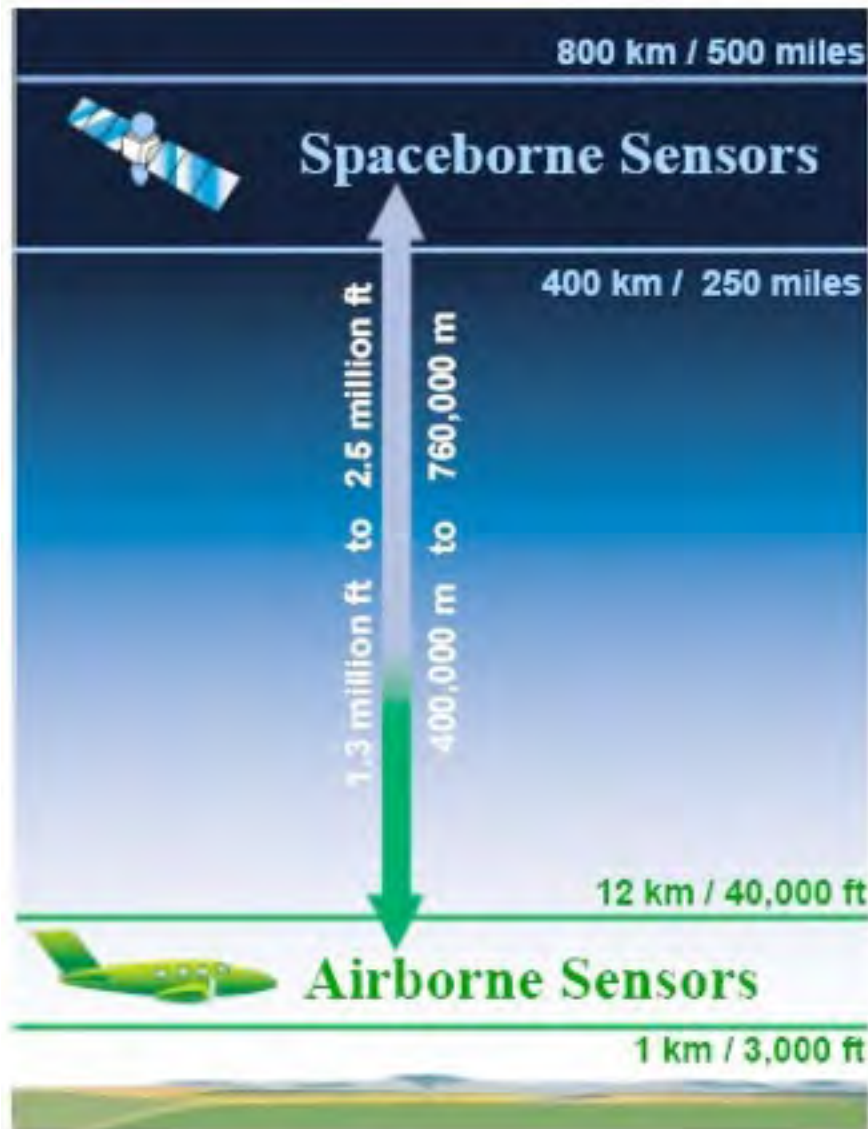

Spaceborne

GSD > 0.80m



Airborne Digital

GSD 0.20m



Airborne Film

GSD 0.10m

Jonas





Spot 5 Japan © Spottimage

Land Observation Satellites

Landsat (NOAA, USA)

SPOT (France)

ERS (ESA, Europe)

Envisat (ESA, Europe)

IRS (India)

JERS (Japan)

RESURS (Russia)

EROS

IKONOS

QuickBird

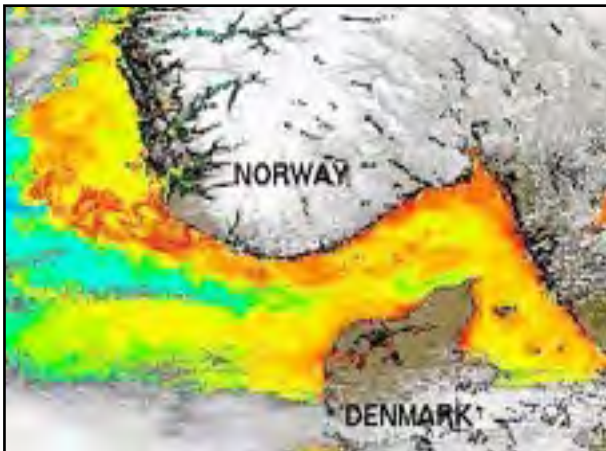

SeaWiFS Norge 2001 © NASA

Marine Observation Satellites

SeaWiFS (NASA, USA)

MOS (Japan)

Okean (Russia)

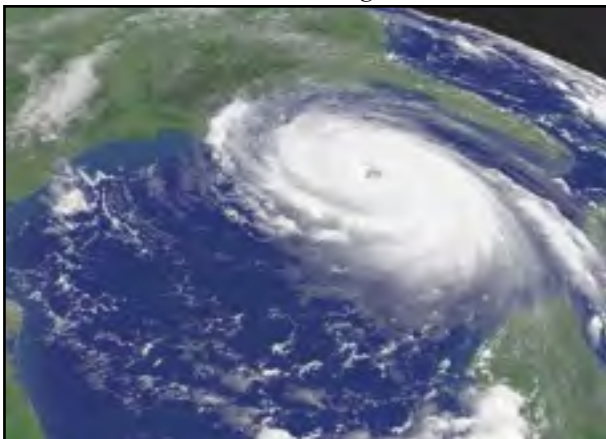

NOAA Katrina 2005

Weather Satellites

NOAA AVHRR (USA)

GOES (NASA/NOAA, USA)

Meteosat (EU)

GMS (Japan)

Meteor (Russia)

Jonas



1E1630

Remote Sensing
2005

Overview

Orbits

Satellites

Landsat

SPOT

Other ERS

Meteorological

Oceanic

Others

Satellite Orbits

- (Near) Polar Orbit
- Sun Synchronous Orbit
- Geosynchronous Orbit
- Inclined Orbit

Jonas



1E1630
Remote Sensing
2005

Overview

Orbits

Satellites

Landsat

SPOT

Other ERS

Meteorological

Oceanic

Others

Orbit Comparison

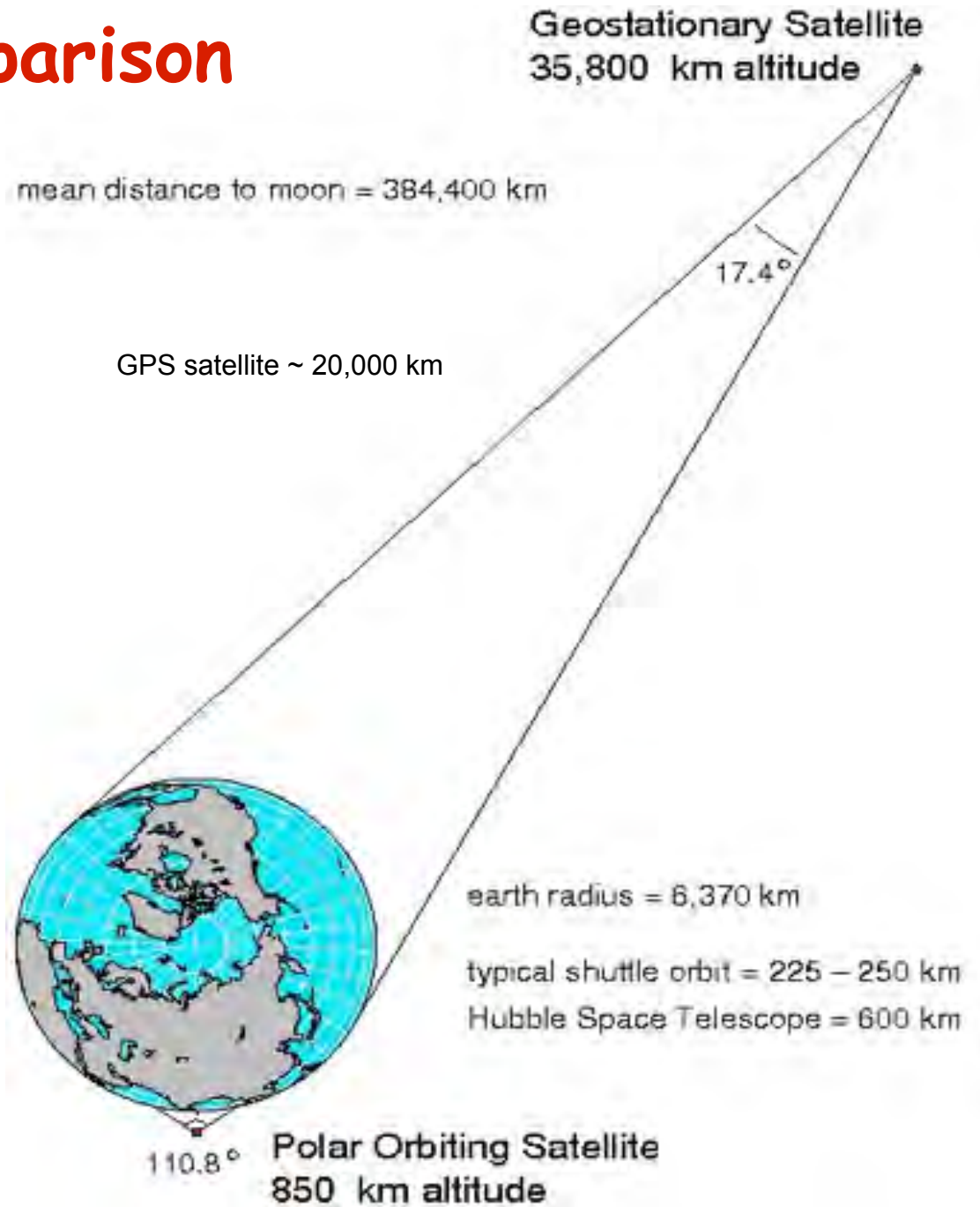

Jonas



1E1630
Remote Sensing
2005

- Overview
- Orbits**
- Satellites
- Landsat
- SPOT
- Other ERS
- Meteorological
- Oceanic
- Others

Sun Synchronous Orbit

These satellites orbit at an altitude between 700 to 800 km. It takes approximately 100 minutes for the satellite to complete one orbit. These orbits allows a satellite to pass over a section of the Earth at the same time of day.

Since there are 365 days in a year and 360 degrees in a circle, it means that the satellite has to shift its orbit by approximately one degree per day.

Usually the orbits are designed to have equatorial pass around 9-10 a.m., to take advantage of the clearer morning skies.

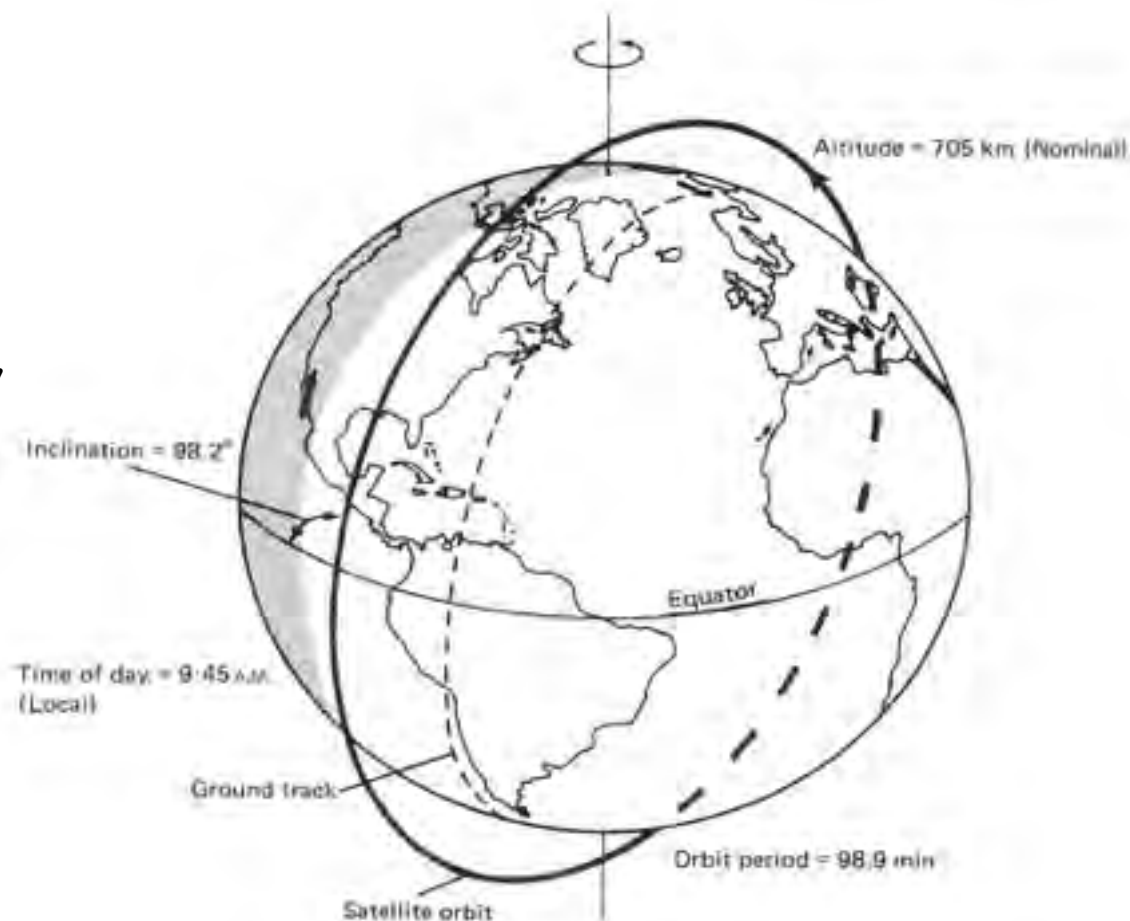

Jonas



1E1630
Remote Sensing
2005

Overview
Orbits
Satellites
Landsat
SPOT
Other ERS
Meteorological
Oceanic
Others

Sun Synchronous, Near-Polar Orbit Satellite Path

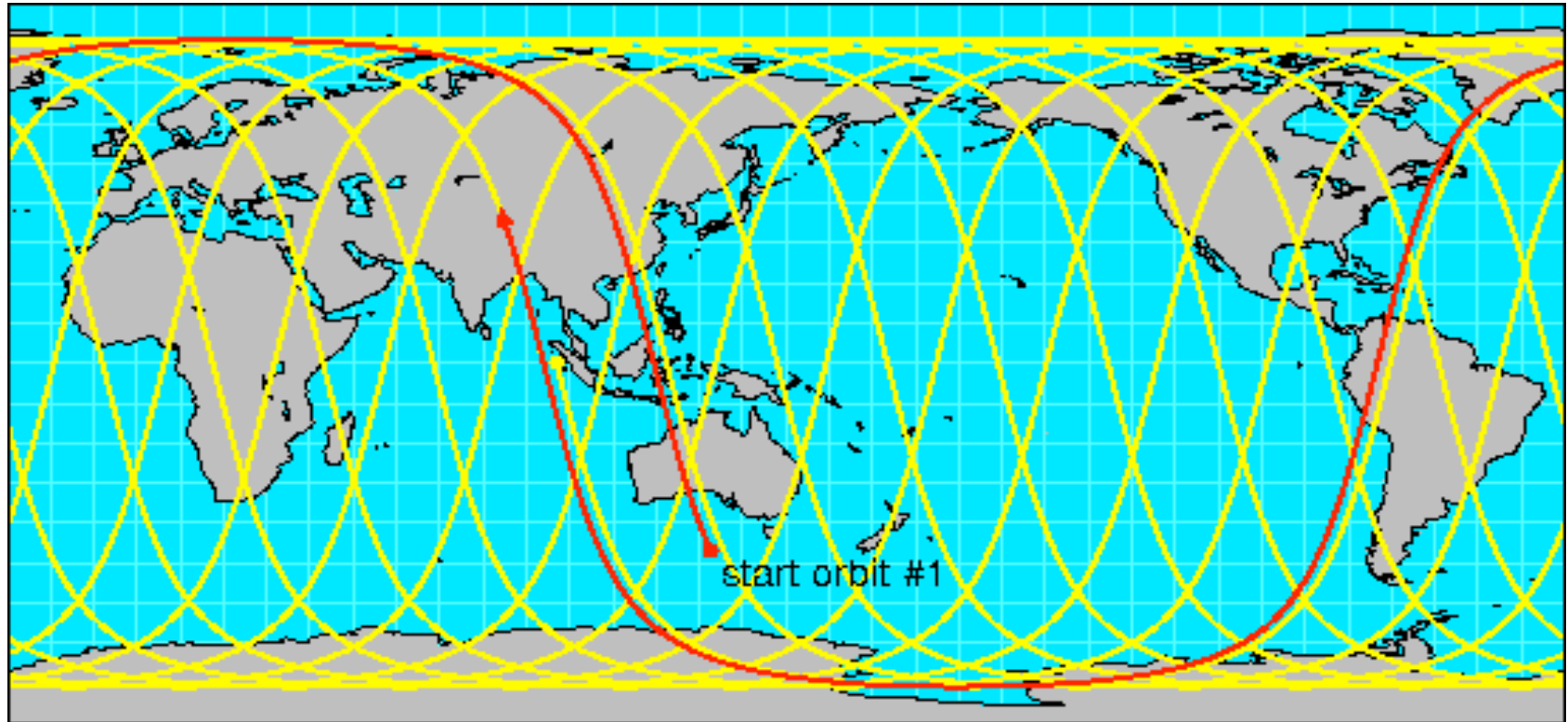

Landsat, Spot and many other earth observation satellites follow this principle.

Jonas



1E1630
Remote Sensing
2005

Overview
Orbits
Satellites
Landsat
SPOT
Other ERS
Meteorological
Oceanic
Others

Geosynchronous Orbit

Sometimes (erroneously) known as geostationary orbits, satellites in these orbits circle the Earth at the same rate as the Earth spins. This would put the satellite at approximately 35,790 km above the Earth.

The satellites are located near the equator since at this latitude, there is a constant force of gravity from all directions.

At other latitudes, the bulge at the center of the Earth would pull on the satellite.

Jonas



1E1630
Remote Sensing
2005

Overview
Orbits
Satellites
Landsat
SPOT
Other ERS
Meteorological
Oceanic
Others

Geosynchronous Orbit

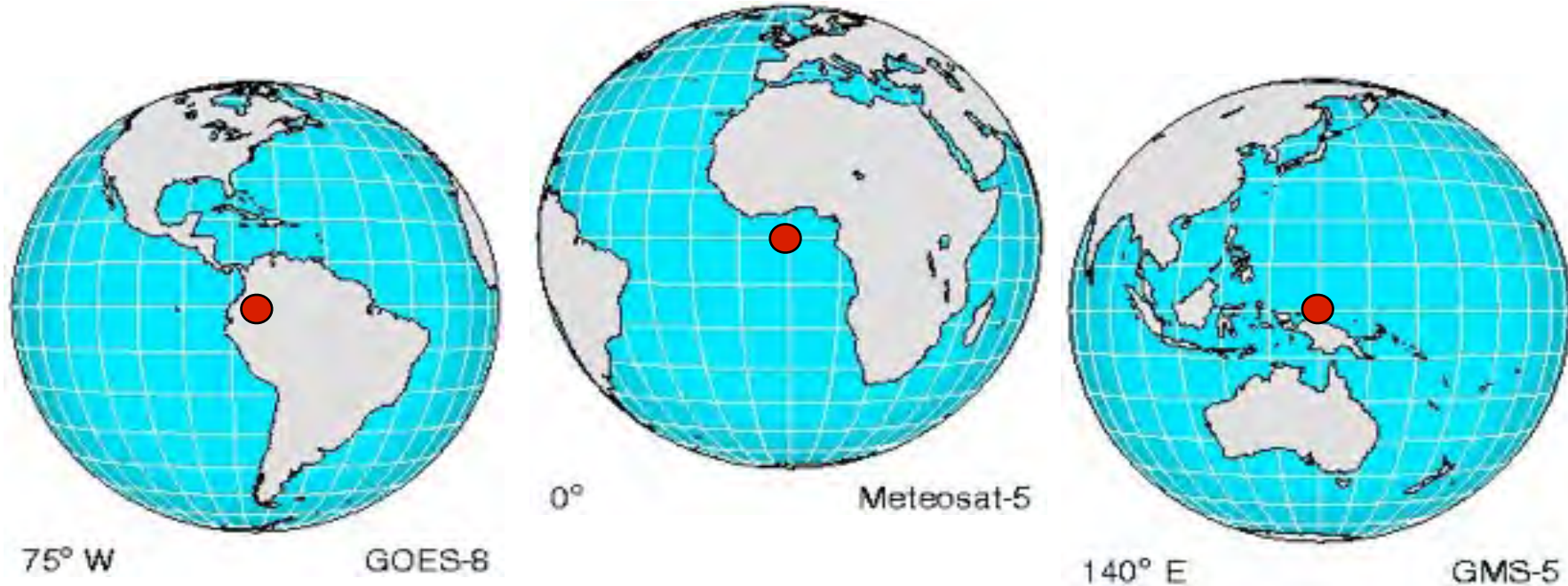

Geosynchronous orbits allow the satellite to continuously observe almost a full hemisphere of the Earth. These satellites are used to study large scale phenomenon such as weather systems. These orbits are also used for communication satellites.

The disadvantage of this type of orbit is that since these satellites are very far away, they have poor resolution.

The other disadvantage is that these satellites have trouble monitoring activities near the poles.

Jonas



1E1630
Remote Sensing
2005

Overview
Orbits
Satellites
Landsat
SPOT
Other ERS
Meteorological
Oceanic
Others

Swath

As a satellite moves around the Earth, the sensor "sees" a certain portion of the Earth's surface; **swath**.

The width of the swath for spaceborne sensors vary between tens of km to hundreds of km wide.

Example: IKONOS 11 km
Landsat 7 185 km

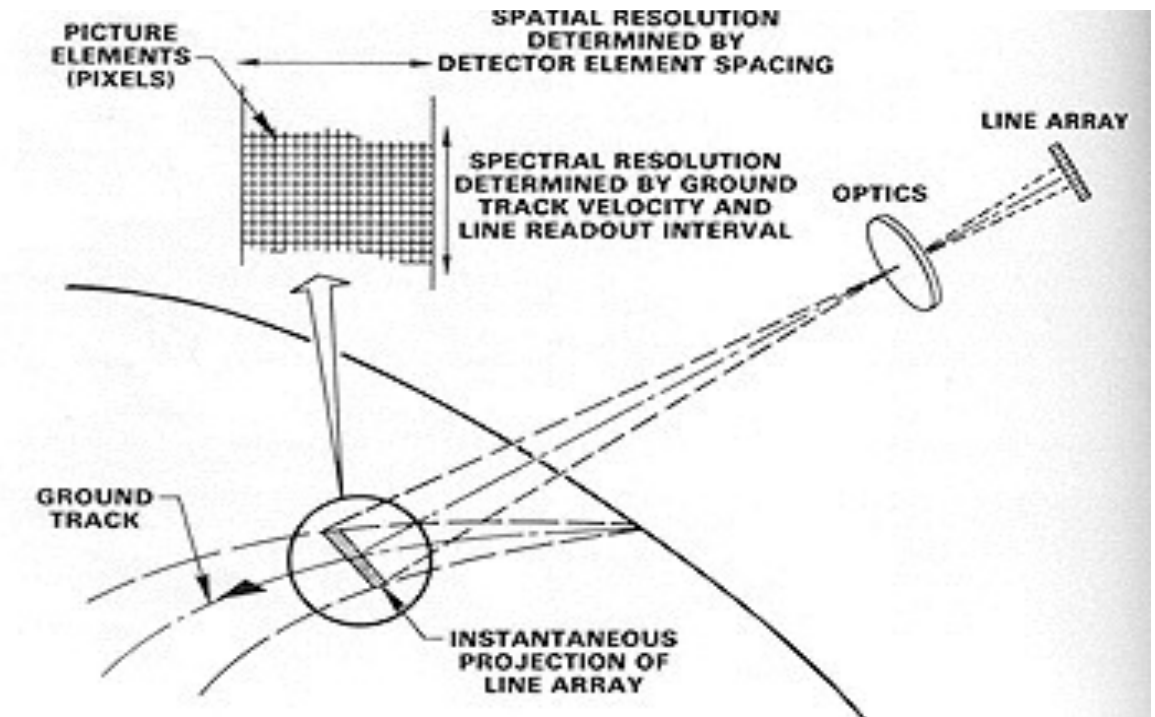

Jonas



1E1630
Remote Sensing
2005

- Overview
- Orbits**
- Satellites
- Landsat
- SPOT
- Other ERS
- Meteorological
- Oceanic
- Others

Coverage

As seen from Earth, it seems as if the satellite is shifting westward because the Earth is rotating (from west to east) beneath it.

This apparent movement allows the satellite to cover a new area with each consecutive pass



(Landsat)

Jonas



1E1630
Remote Sensing
2005

Overview
Orbits
Satellites
Landsat
SPOT
Other ERS
Meteorological
Oceanic
Others

Coverage

The satellite's orbit and the rotation of the Earth allow complete coverage of the Earth's surface, after it has completed one cycle of orbits (eg. 16 days for Landsat 7).

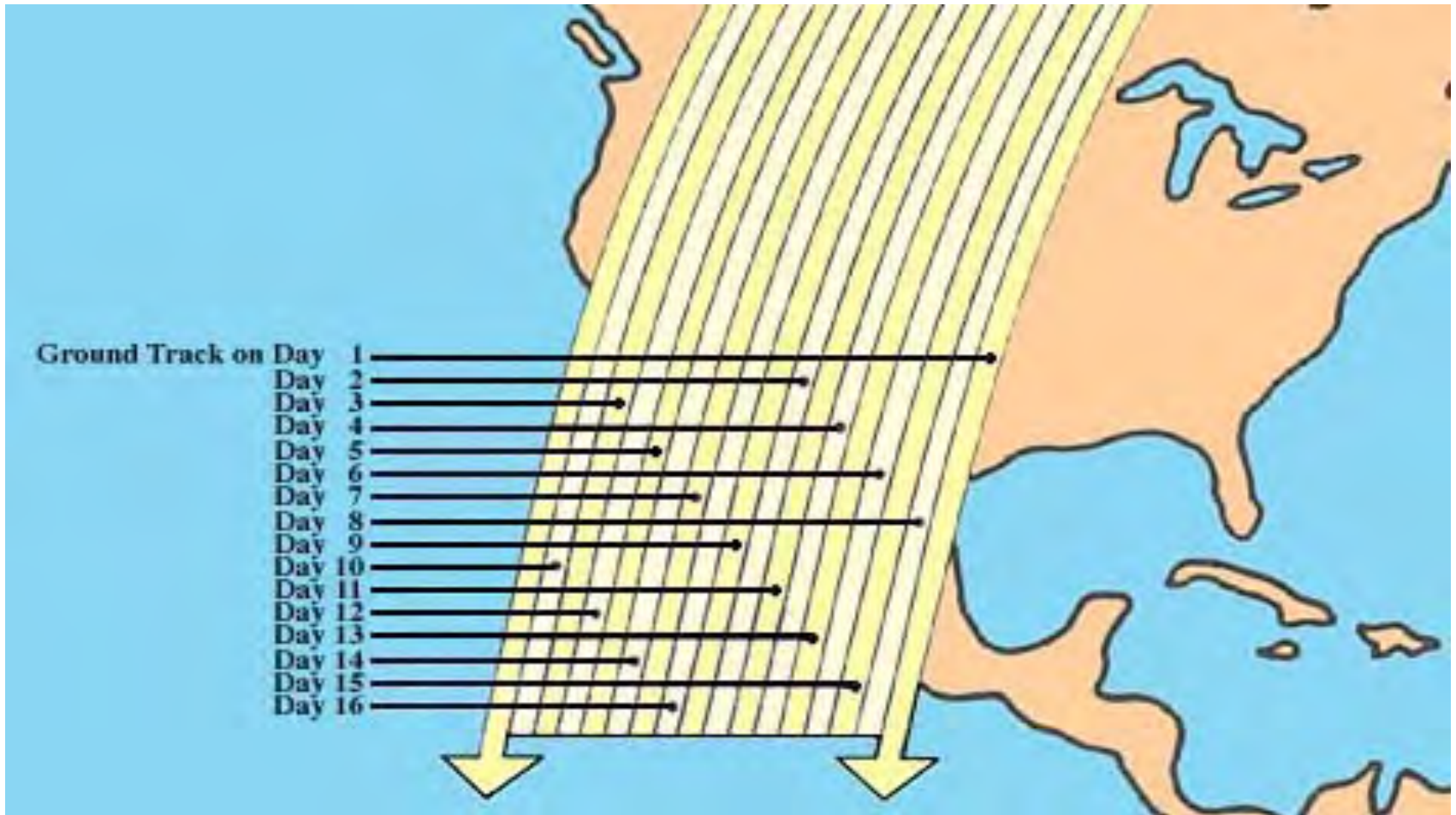

(Landsat)

Jonas



1E1630
Remote Sensing
2005

- Overview
- Orbits**
- Satellites
- Landsat
- SPOT
- Other ERS
- Meteorological
- Oceanic
- Others

Polar Coverage

Near-polar orbital satellites will cover the near-polar regions on every orbit.



Jonas



1E1630
Remote Sensing
2005

Overview
Orbits
Satellites
Landsat
SPOT
Other ERS
Meteorological
Oceanic
Others

Polar Coverage

Depending on the swath width and the orbit, near-polar orbital satellites may **not** cover the actual poles!
(Eg. Landsat does not cover latitudes 82-90 degrees).

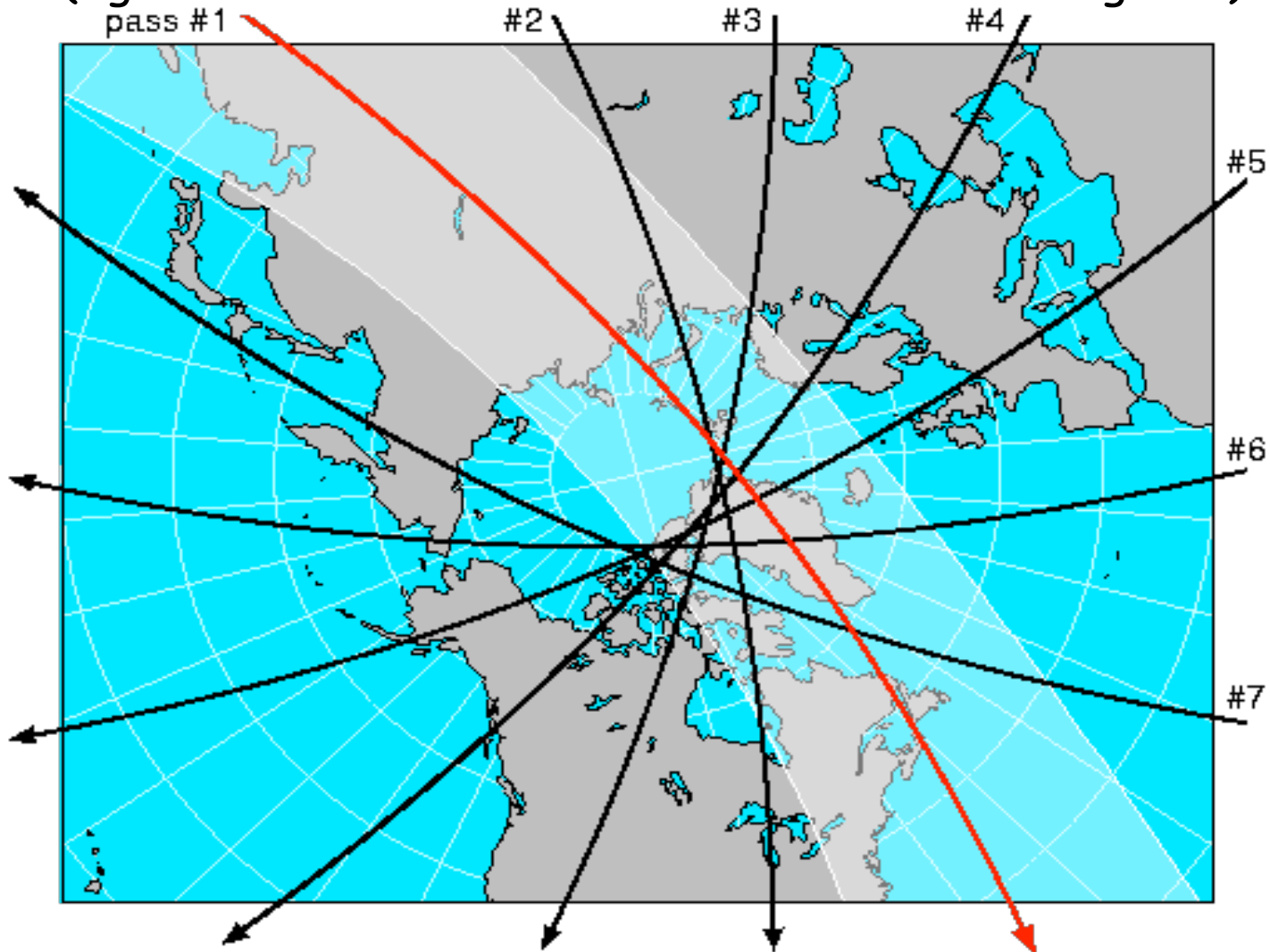

Jonas



1E1630
Remote Sensing
2005

Overview

Orbits

Satellites

Landsat

SPOT

Other ERS

Meteorological

Oceanic

Others

Ascending and Descending

The satellite travels northward on one side of the earth and southward on the second half of its orbit.

This is called the **ascending** and **descending** passes.

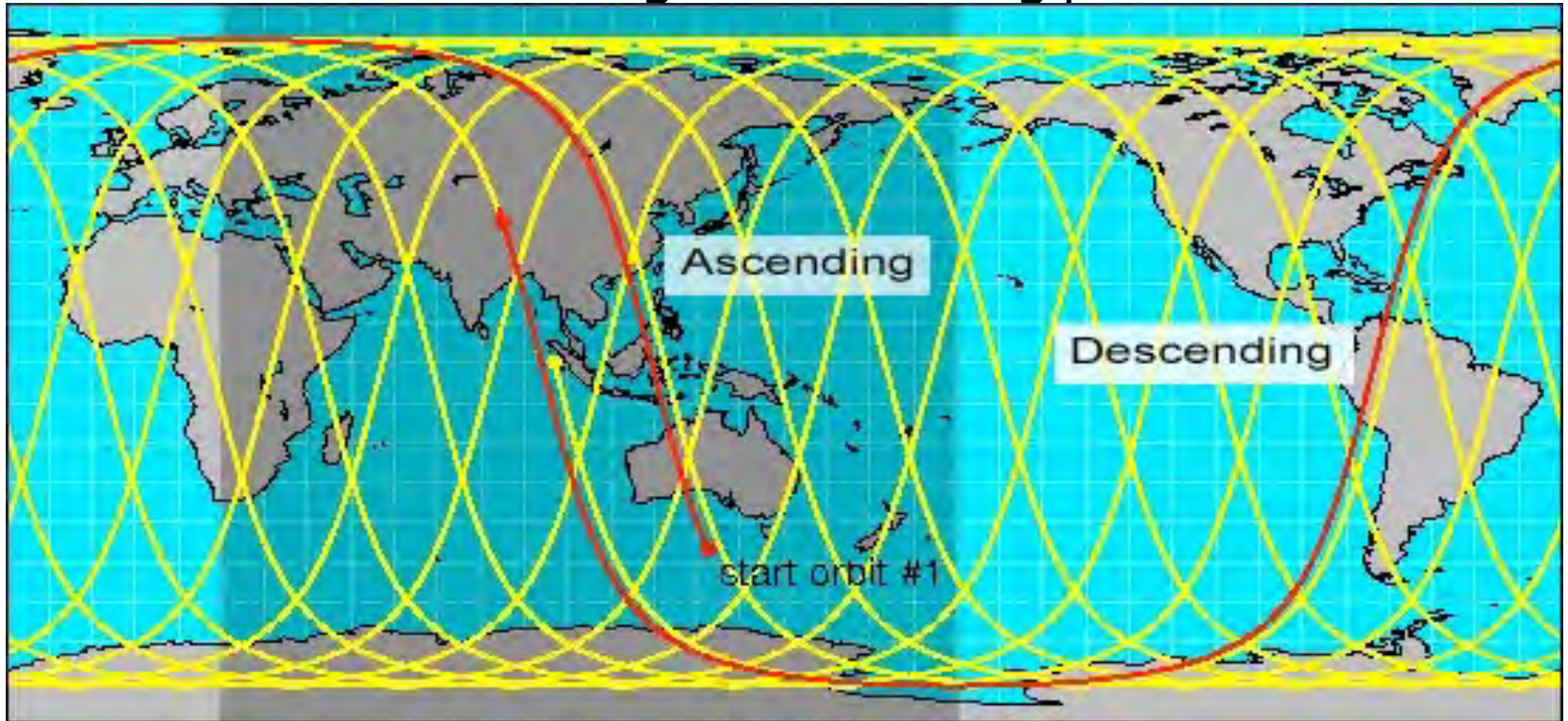

If the orbit is also sun-synchronous, the ascending pass is usually on the shadowed side of the Earth while the descending pass is on the sunlit side.

Jonas



1E1630
Remote Sensing
2005

Overview

Orbits

Satellites

Landsat

SPOT

Other ERS

Meteorological

Oceanic

Others

Ascending and Descending

Passive sensors recording reflected solar energy only image the surface on a **descending** pass, when solar illumination is available.

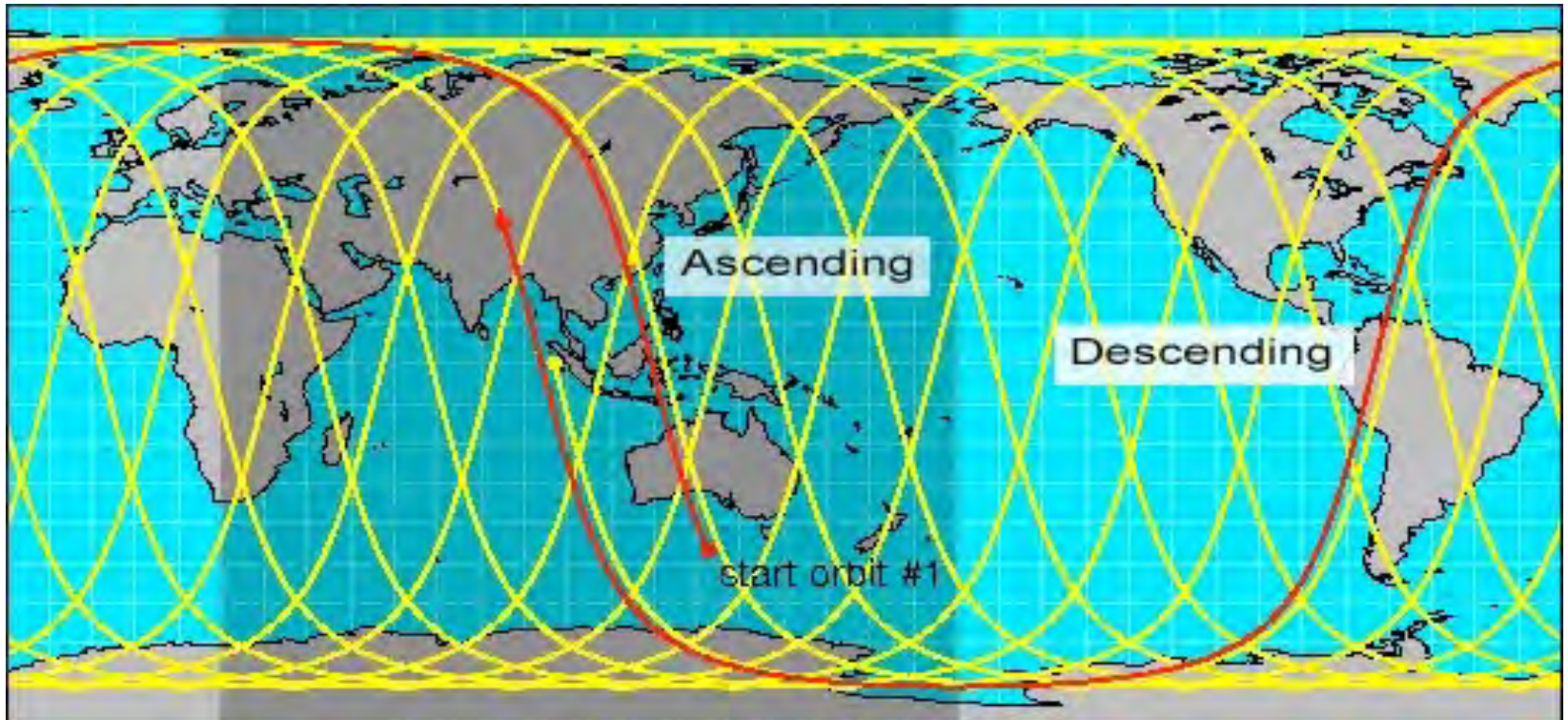

Active sensors which provide their own energy, or passive sensors that record emitted (e.g. thermal) radiation, can also image the surface on **ascending** passes.

Jonas



1E1630
Remote Sensing
2005

Overview
Orbits
Satellites
Landsat
SPOT
Other ERS
Meteorological
Oceanic
Others

Temporal Resolution

An **Orbit Cycle** will be completed when the satellite retraces its path, passing over the same point on the Earth's surface directly below the satellite for a second time.

The time interval required for the satellite to complete its orbit cycle is not always the same as the **Revisit Period**, for satellites with off-nadir viewing capacities, or in polar regions for polar orbiting satellites.

The temporal resolution is an important consideration for a number of monitoring applications, especially when frequent imaging is required.

Satellite	Orbit Cycle	Revisit Period
Landsat 7	16 days	(no off-nadir)
SPOT 5	26 days	1-4 days (off nadir)
IKONOS	144 days	3-5 days (off nadir)

Jonas



1E1630
Remote Sensing
2005

Overview
Orbits
Satellites
Landsat
SPOT
Other ERS
Meteorological
Oceanic
Others

Temporal Resolution

The **Absolute Temporal Resolution** is equal to the Orbit Cycle interval. However, some satellite systems (SPOT, IKONOS etc.) are able to point their sensors in off-nadir angles, in order to image the same area between different satellite passes, separated by periods from 1-5 days.

So the **Actual Temporal Resolution** of a sensor depends on a variety of factors:

- Orbit cycle time
- Sensor capabilities (pointing)
- Swath overlap ("strip overlap")
- Latitude (polar regions get revisited more often)

Jonas



1E1630
Remote Sensing
2005

Overview
Orbits
Satellites
Landsat
SPOT
Other ERS
Meteorological
Oceanic
Others

Satellite Overview

There are hundreds of remote sensing satellites in use today, so this overview of satellite systems will focus on a **few** of those most commonly used today.

However, research often include long-term change studies (i.e. glacier melting, deforestation, climate change, urban growth etc.) and for those studies **older satellite images are often used** (there are some 1.3 million old MSS and RBV scenes available).

Therefore, a review of some older satellite systems is also necessary.



Spot 5 © SPOT Image

Jonas



1E1630
Remote Sensing
2005

Overview
Orbits
Satellites
Landsat
SPOT
Other ERS
Meteorological
Oceanic
Others

Jonas



1E1630
Remote Sensing
2005

- Overview
- Orbits
- Satellites**
- Landsat
- SPOT
- Other ERS
- Meteorological
- Oceanic
- Others



Landsat

Jonas



1E1630
Remote Sensing
2005

- Overview
- Orbits
- Satellites
- Landsat**
- SPOT
- Other ERS
- Meteorological
- Oceanic
- Others

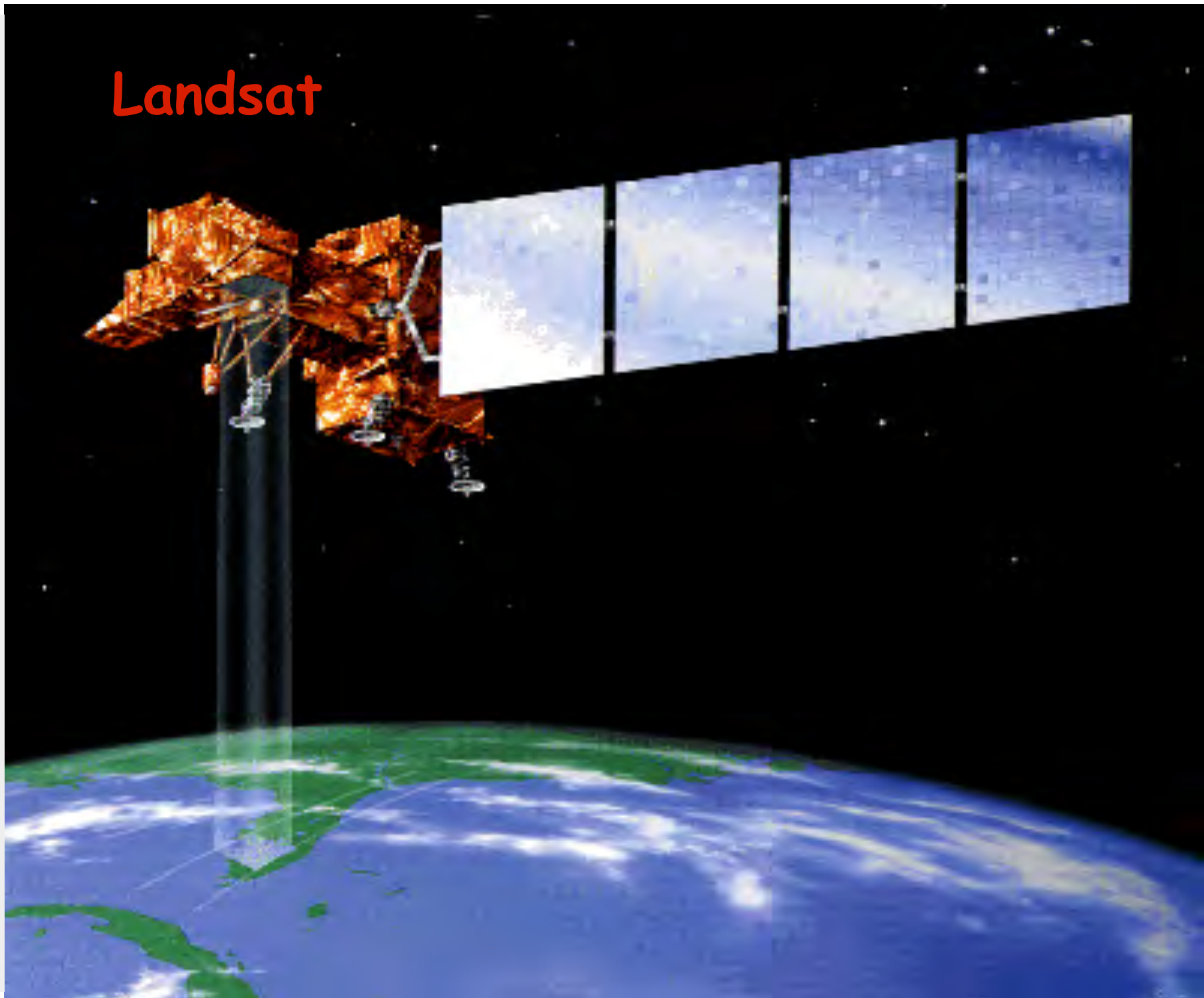

Landsat Program

Landsat (originally ERTS) has been in operation since 1972. Basically, it has been through three generations so far (Landsat 1-3, Landsat 4-5, and Landsat 6-7).

Today, Landsat 5 and Landsat 7 are both partly operational.

Jonas



1E1630
Remote Sensing
2005

- Overview
- Orbits
- Satellites
- Landsat**
- SPOT
- Other ERS
- Meteorological
- Oceanic
- Others

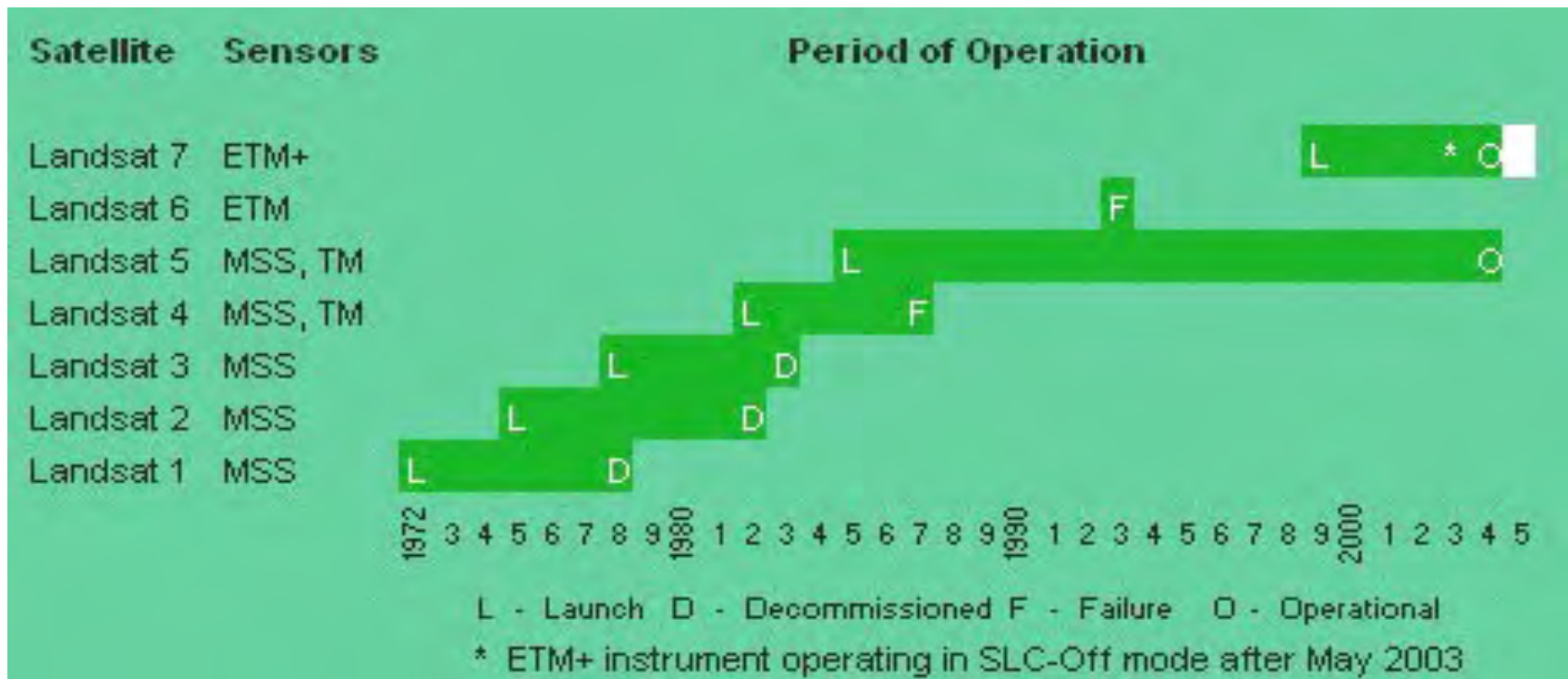

Landsat Satellite Generations

Satellite	Launch	Dead	RBV bands	MSS bands	TM bands	Orbit
Landsat-1	Jul 23, 1972	Jan 6, 1978	1-3 (simultaneous)	4-7	<i>none</i>	18 days 900 km
Landsat-2	Jan 22, 1975	Feb 25, 1982	1-3 (simultaneous)	4-7	<i>none</i>	18 days 900 km
Landsat-3	Mar 5, 1978	Mar 31, 1983	A-D (side-by-side)	4-8	<i>none</i>	18 days 900 km
Landsat-4	Jul 16, 1982	Aug 1993	<i>none</i>	1-4	1-7	16 days 705 km
Landsat-5	Mar 1, 1984		<i>none</i>	1-4	1-7	16 days 705 km
<i>Landsat-6</i>	<i>Oct 5, 1993</i>	<i>Oct 5, 1993</i>	<i>none</i>	<i>none</i>	<i>1-7 + pan (ETM)</i>	<i>16 days 705 km</i>
Landsat-7	Apr 15, 1999	<i>SLC off</i>	<i>none</i>	<i>none</i>	1-7 + pan (ETM+)	16 days 705 km

Jonas



1E1630
Remote Sensing
2005

Overview
Orbits
Satellites
Landsat
SPOT
Other ERS
Meteorological
Oceanic
Others

Sensors on Landsat 1-3

RBV (Return Beam Vidicon)

Landsat 1-2 had three (B,G,R-NIR) overlapping RBVs, 80 m res.

Landsat 3 had four side-by-side panchromatic RBVs, 30 m res.

MSS (Multi-Spectral Scanners)

4	0.5 - 0.6 μm	79/82 m res.
5	0.6 - 0.7 μm	79/82 m res.
6	0.7 - 0.8 μm	79/82 m res.
7	0.8 - 1.1 μm	79/82 m res.
8	10.4 - 12.6 μm	240 m res. (only Landsat 3, but failed shortly after launch)

Radiometric resolution: 6 bits (64 values)

Temporal resolution: 18 days

Altitude: 900 km

Orbital time: 103 minutes.

Swath: 185 km

Jonas



1E1630
Remote Sensing
2005

Overview
Orbits
Satellites
Landsat
SPOT
Other ERS
Meteorological
Oceanic
Others

Landsat MSS Sensor Configuration

Because of the small FoV of 11.56 degrees, an oscillating instead of spinning mirror is employed. The mirror oscillates with a frequency of 33 kHz.

Six lines are scanned with each mirror oscillation. This arrangement requires 4 arrays (one for each band) of 6 detectors each (one for each line).

A nominal Landsat MSS scene consists of 2340 scan lines with about 3240 pixels per line
- or about 7 581 600 pixels per channel.
With four channels, each scene contains over 30 million registrations.

Jonas



1E1630
Remote Sensing
2005

[Overview](#)
[Orbits](#)
[Satellites](#)
[Landsat](#)
[SPOT](#)
[Other ERS](#)
[Meteorological](#)
[Oceanic](#)
[Others](#)

MSS SCANNING ARRANGEMENT

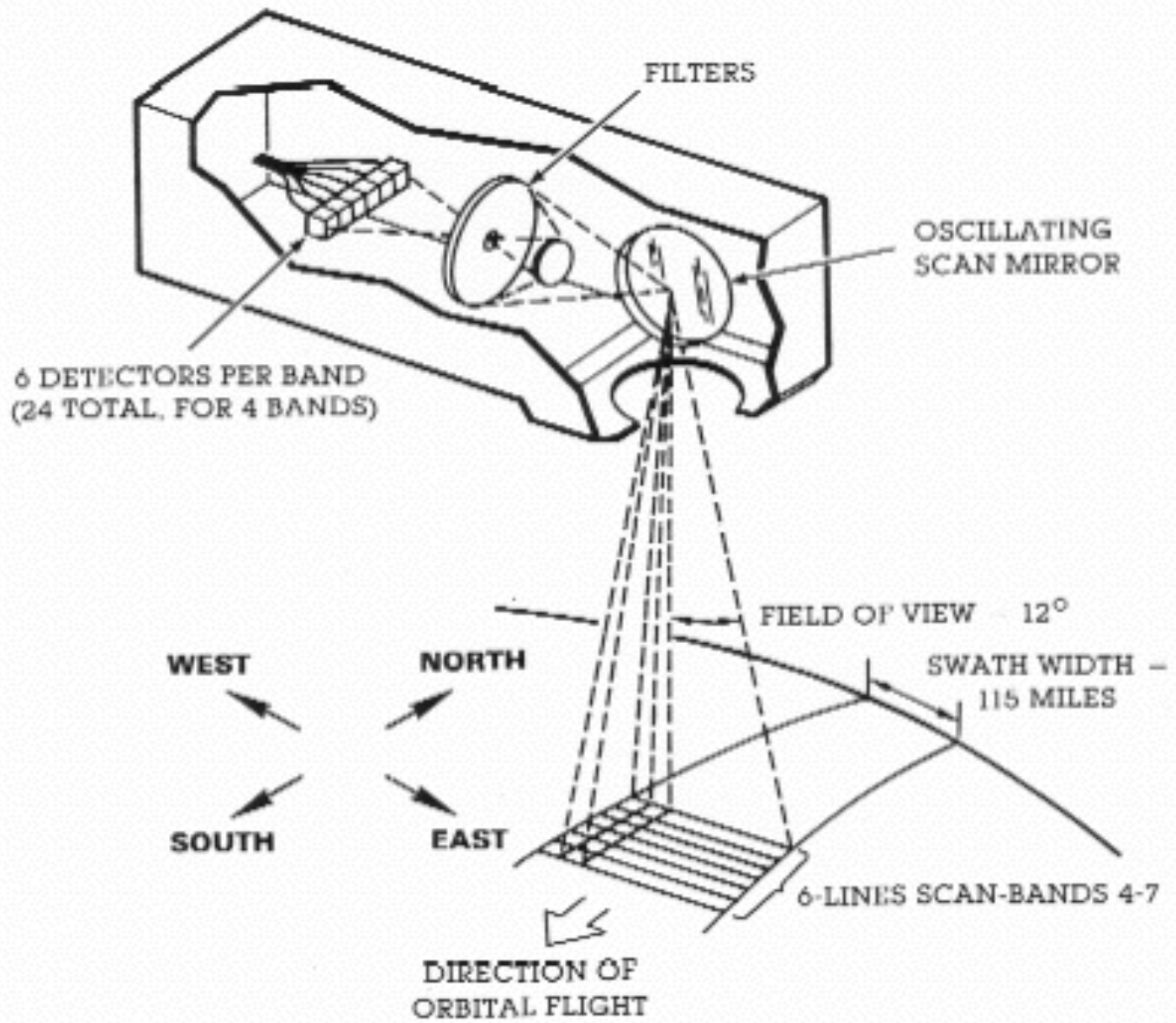

Jonas



1E1630
Remote Sensing
2005

- Overview
- Orbits
- Satellites
- Landsat**
- SPOT
- Other ERS
- Meteorological
- Oceanic
- Others

Scan Line Correction

The Scan Line Corrector (SLC) on Landsat 7 was damaged in 2003 and has not been possible to repair.

Landsat 7 now runs in SLC-off mode, only the central parts of the image are usable.

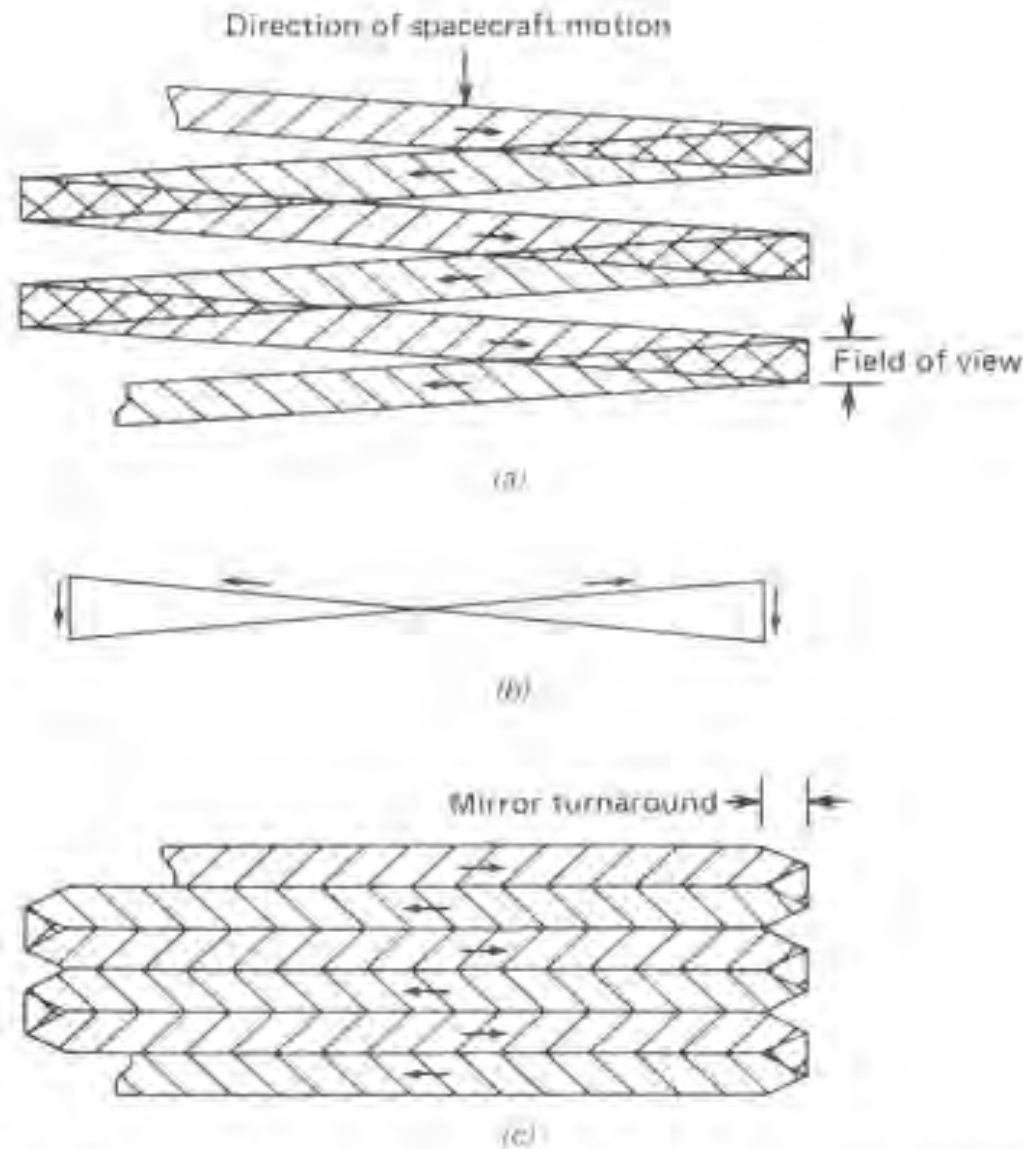

Figure 6.15 Schematic of TM scan line correction process: (a) uncompensated scan lines; (b) correction for satellite motion; (c) compensated scan lines. (Adapted from NASA diagram.)

Jonas



1E1630
Remote Sensing
2005

Overview
Orbits
Satellites
Landsat
SPOT
Other ERS
Meteorological
Oceanic
Others

Improvements to next generation (4-5)

The RBVs were retired.

The **Thematic Mapper (TM)** sensors were introduced, with higher geometric resolution, better spectral resolution (more and narrower bands covering more of the spectrum) and better radiometric resolution (8 bit).

Also more detectors (16x7 + 4, compared to 6x4).

Lower orbit (for better resolution and possibility to maintenance through the Space Shuttle).

Instead of 18 day cycle and 1 day between adjacent paths, now a **16 day cycle** and 7 days between adjacent paths.

To keep the 185 km swath from a lower orbit, the Field-of-View angle increased to 14.92 degrees.

The MSS remained basically unchanged.

Jonas



1E1630
Remote Sensing
2005

Overview
Orbits
Satellites
Landsat
SPOT
Other ERS
Meteorological
Oceanic
Others

Sensors on Landsat 4-5

MSS (Multi-Spectral Scanners) 6 bits

1	0.5 - 0.6 μm	82 m res.
2	0.6 - 0.7 μm	82 m res.
3	0.7 - 0.8 μm	82 m res.
4	0.8 - 1.1 μm	82 m res.

TM (Thematic Mapper) 8 bits

1	0.45 - 0.52 μm	30 m res. (Blue)
2	0.52 - 0.60 μm	30 m res. (Green)
3	0.63 - 0.69 μm	30 m res. (Red)
4	0.76 - 0.90 μm	30 m res. (Near IR)
5	1.55 - 1.75 μm	30 m res. (Mid IR)
6	10.4 - 12.5 μm	120 m res. (Thermal IR)
7	2.08-2.35 μm	30 m res. (Mid IR)

Temporal resolution: 16 day cycle (233 paths)

Altitude: 705 km

Orbital time: 99 minutes.

Swath: 185 km

Jonas



1E1630
Remote Sensing
2005

Overview
Orbits
Satellites
Landsat
SPOT
Other ERS
Meteorological
Oceanic
Others

Sensors on Landsat 6

ETM (Enhanced Thematic Mapper)

8+1 bits (high/low)

1	0.45 - 0.52 μm	30 m res. (Blue)
2	0.52 - 0.60 μm	30 m res. (Green)
3	0.63 - 0.69 μm	30 m res. (Red)
4	0.76 - 0.90 μm	30 m res. (Near IR)
5	1.55 - 1.75 μm	30 m res. (Mid IR)
6	10.4 - 12.5 μm	120 m res. (Thermal IR)
7	2.08-2.35 μm	30 m res. (Mid IR)

+ 8 0.50 - 0.90 μm 15 m res. (Panchromatic)

+ Improvement in Gain settings from the ground.

Temporal resolution: 16 day cycle (233 paths)

Altitude: 705 km

Orbital time: 99 minutes.

Swath: 185 km

Field-of-View angle: 14.92 degrees

Jonas



1E1630
Remote Sensing
2005

Overview
Orbits
Satellites
Landsat
SPOT
Other ERS
Meteorological
Oceanic
Others

Landsat 7

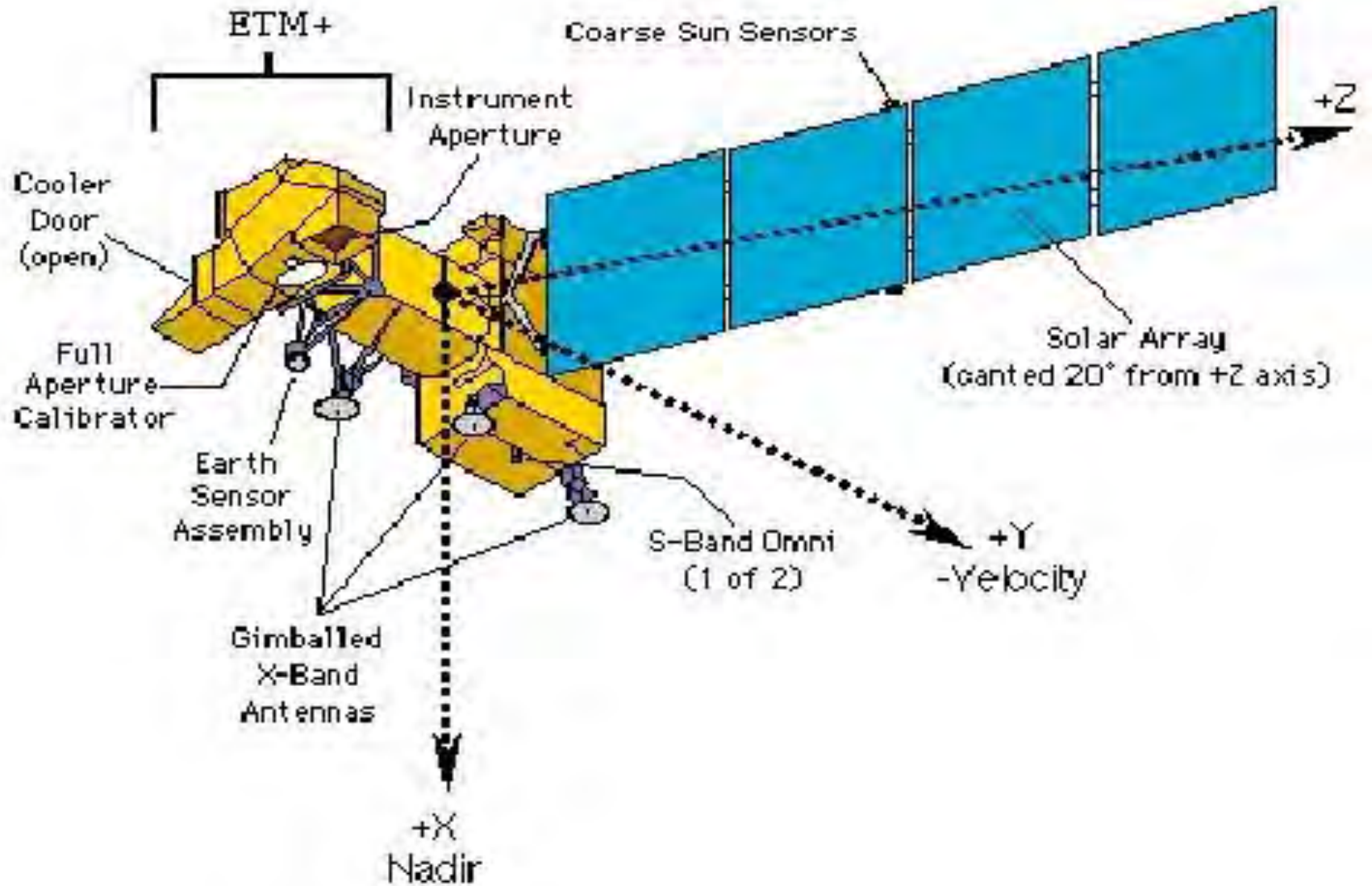

Jonas



1E1630
Remote Sensing
2005

- Overview
- Orbits
- Satellites
- Landsat**
- SPOT
- Other ERS
- Meteorological
- Oceanic
- Others

Sensors on Landsat 7

ETM+ (Enhanced Thematic Mapper)

8+1 bits (high/low)

1	0.45 - 0.52 μm	30 m res. (Blue)
2	0.52 - 0.60 μm	30 m res. (Green)
3	0.63 - 0.69 μm	30 m res. (Red)
4	0.76 - 0.90 μm	30 m res. (Near IR)
5	1.55 - 1.75 μm	30 m res. (Mid IR)
+ 6	10.4 - 12.5 μm	60 m res. (Thermal IR)
7	2.08-2.35 μm	30 m res. (Mid IR)
8	0.50 - 0.90 μm	15 m res. (Panchromatic)

Gain settings from the ground.

Temporal resolution: 16 day cycle (233 paths)

Altitude: 705 km

Orbital time: 99 minutes.

Swath: 185 km

Field-of-View angle: 14.92 degrees

SLC damaged in 2003

Jonas



1E1630
Remote Sensing
2005

Overview
Orbits
Satellites
Landsat
SPOT
Other ERS
Meteorological
Oceanic
Others

Landsat 7 ETM+ scene. (New York, 185 x 185 km)

Jonas



1E1630
Remote Sensing
2005

[Overview](#)
[Orbits](#)
[Satellites](#)
[Landsat](#)
[SPOT](#)
[Other ERS](#)
[Meteorological](#)
[Oceanic](#)
[Others](#)





Landcover changes in the Rwenzori Mountains: the glaciers retreat

Thomas Gumbricht, www.mapjourney.com

FAO Information Products for the Nile Basin, GPC/INT/945/ITA



East Africa and the Rift Valley

East Africa and the two arms of the Rift Valley enclosing Lake Victoria between them. The Eastern Rift has several volcanic mountains – Kilimanjaro, Kenya, Elgon, The Western Rift instead contains a block mountain – Rwenzori.





Mt. Kilimangiaro

East Africa and the Rift Valley

Detail showing the Eastern arm of the Rift Valley, with the volcanic mountains Kilimanjaro, Kenya and Elgon.

Mt. Kenya

Mt. Elgon





Mountain Rwenzori straddling the Uganda- DRC border



MODIS satellite image showing the Rwenzori Mountains. The Rwenzori Mountains lay in the Western arm of the East African Rift Valley, and is a block mountain (it is not a volcanic mountain)



Mountain Rwenzori straddling the Uganda- DRC border

TERRAASTER satellite image showing the Rwenzori Mountains. The edges of the Rift valley can be seen in the upper part of the image.





Glaciers in the Rwenzori Mountains: a reinterpretation

Photograph by Sella taken the 12th of July 1906 from Stairs Peak, showing Mount Baker and Mount Stanley.

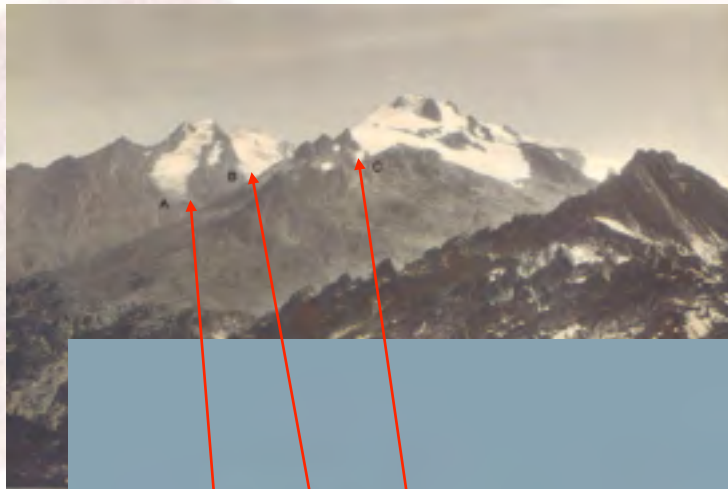

Satellite generated image of the peaks of the Rwenzori Mountains (2005), also showing glacial extents in 1906 and 1955.

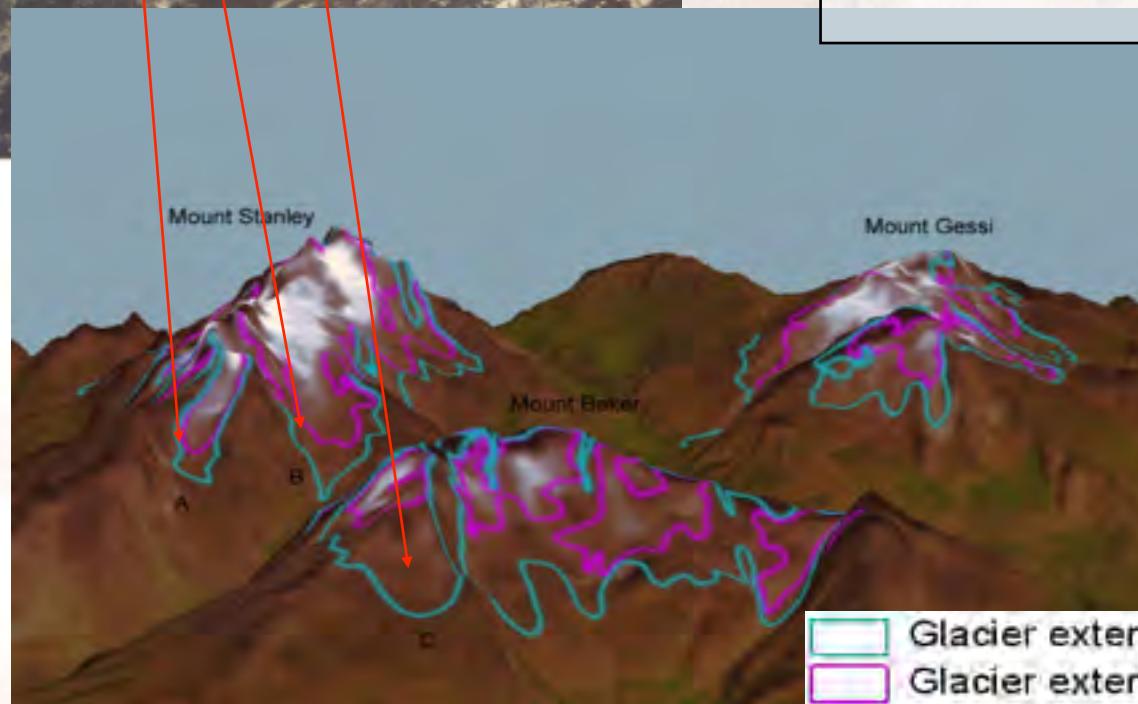

Duke of Abruzzi expedition peak map from 1906

Map published in Geographical Journal, 1907. Reprint by A.A. Michieli, Milan, 1937.

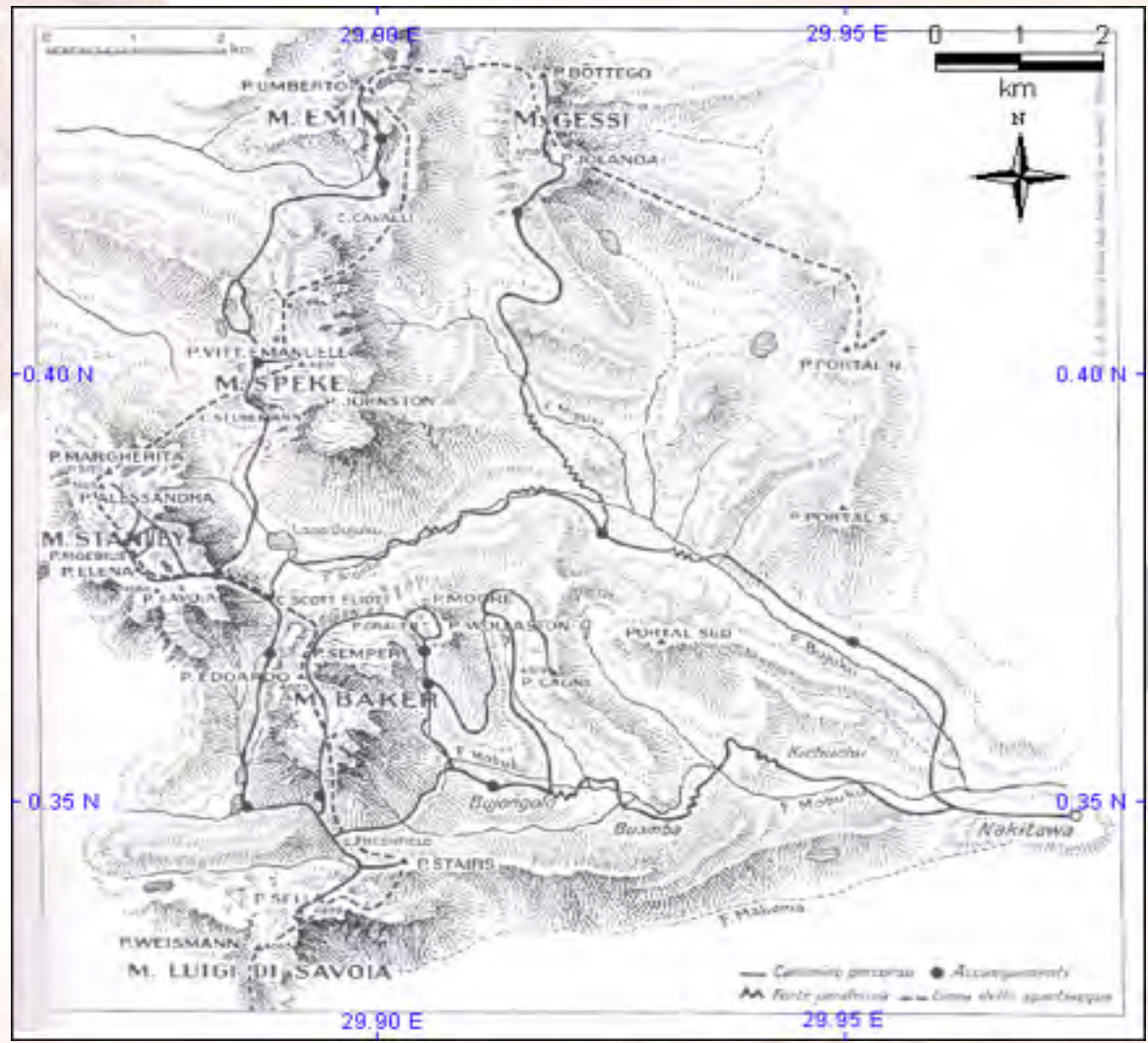



Duke of Abruzzi expedition peak map from 1906

The extent of the glaciers 1906 as mapped by the Duke of Abruzzi expedition. Interpreted by Kaser and Nogglér, 1996.

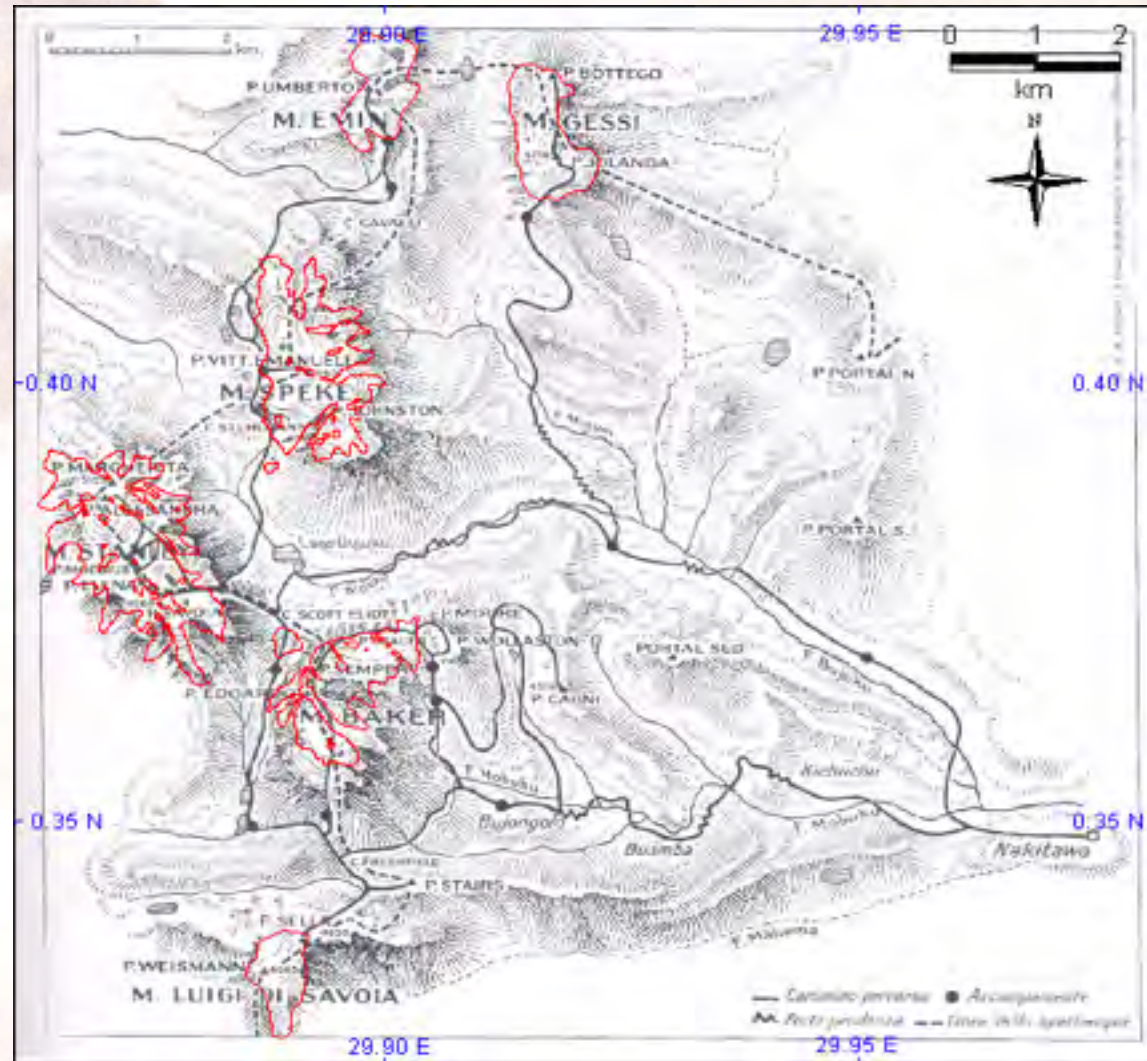



Aerial photograph acquired June 1955

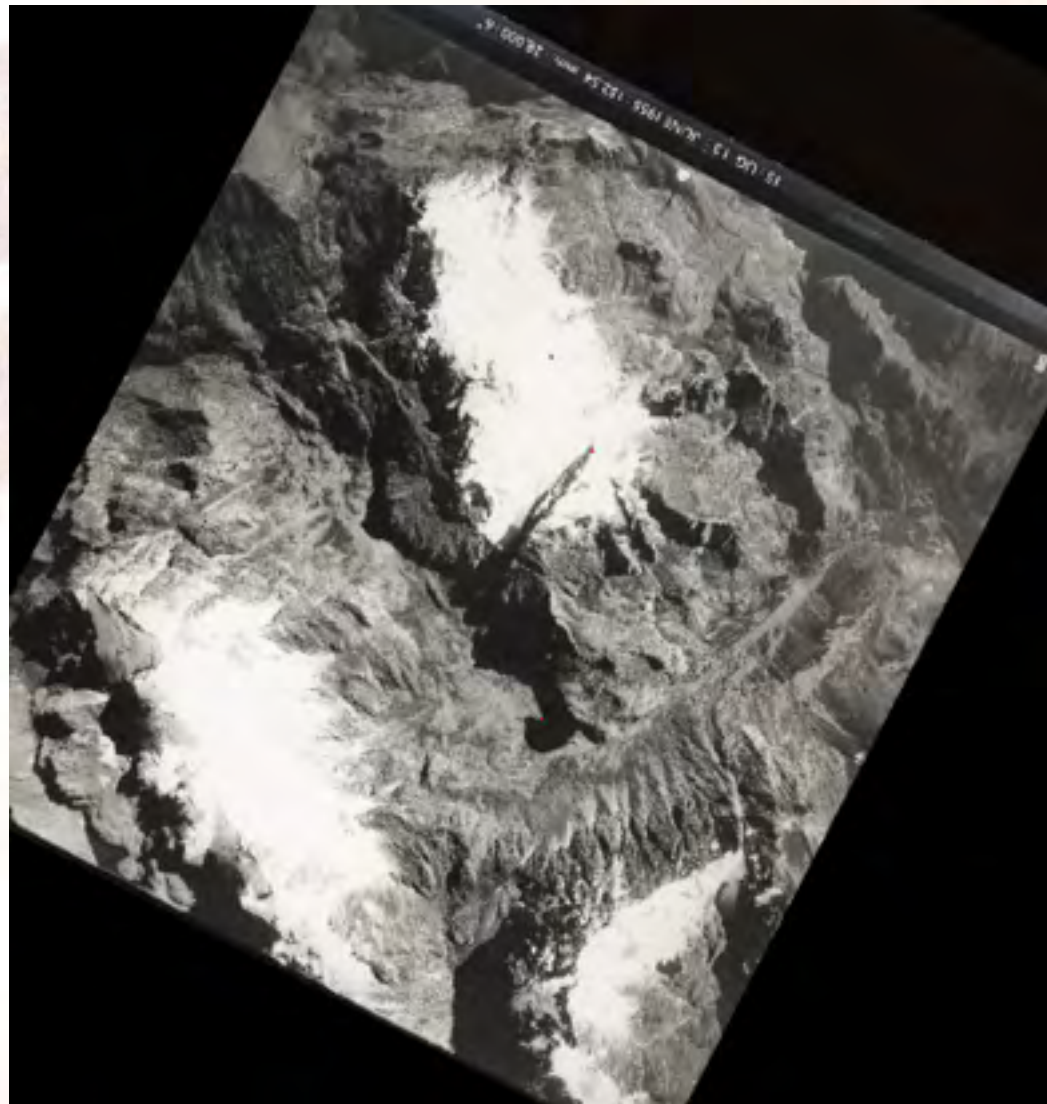



Landsat TM satellite image acquired 7th of August 1987

In this satellite image the glaciers stand out as light blue. Clouds are white.

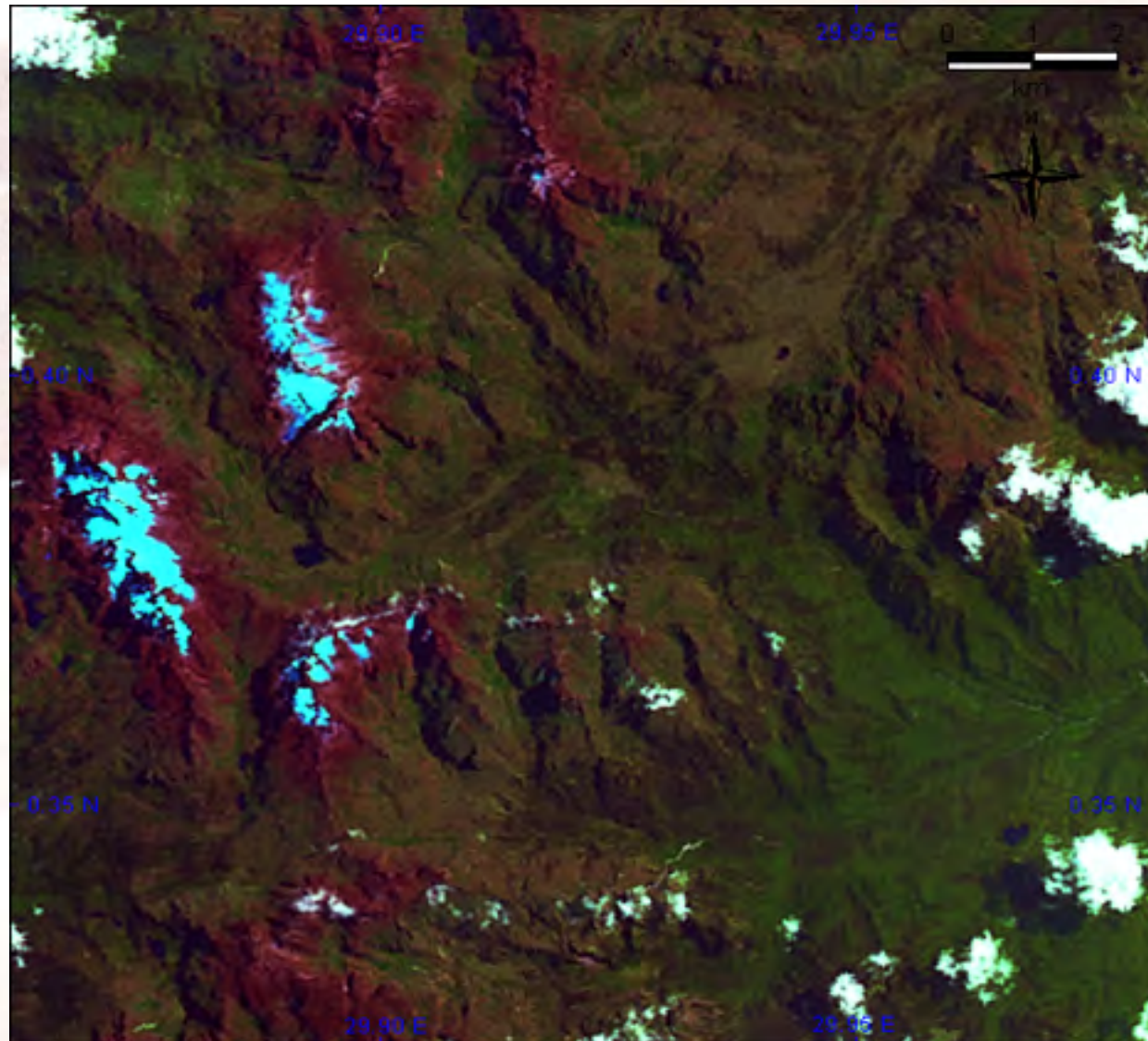



Landsat TM satellite image acquired 7th of August 1987

This image shows the snow content (red) in the satellite image.

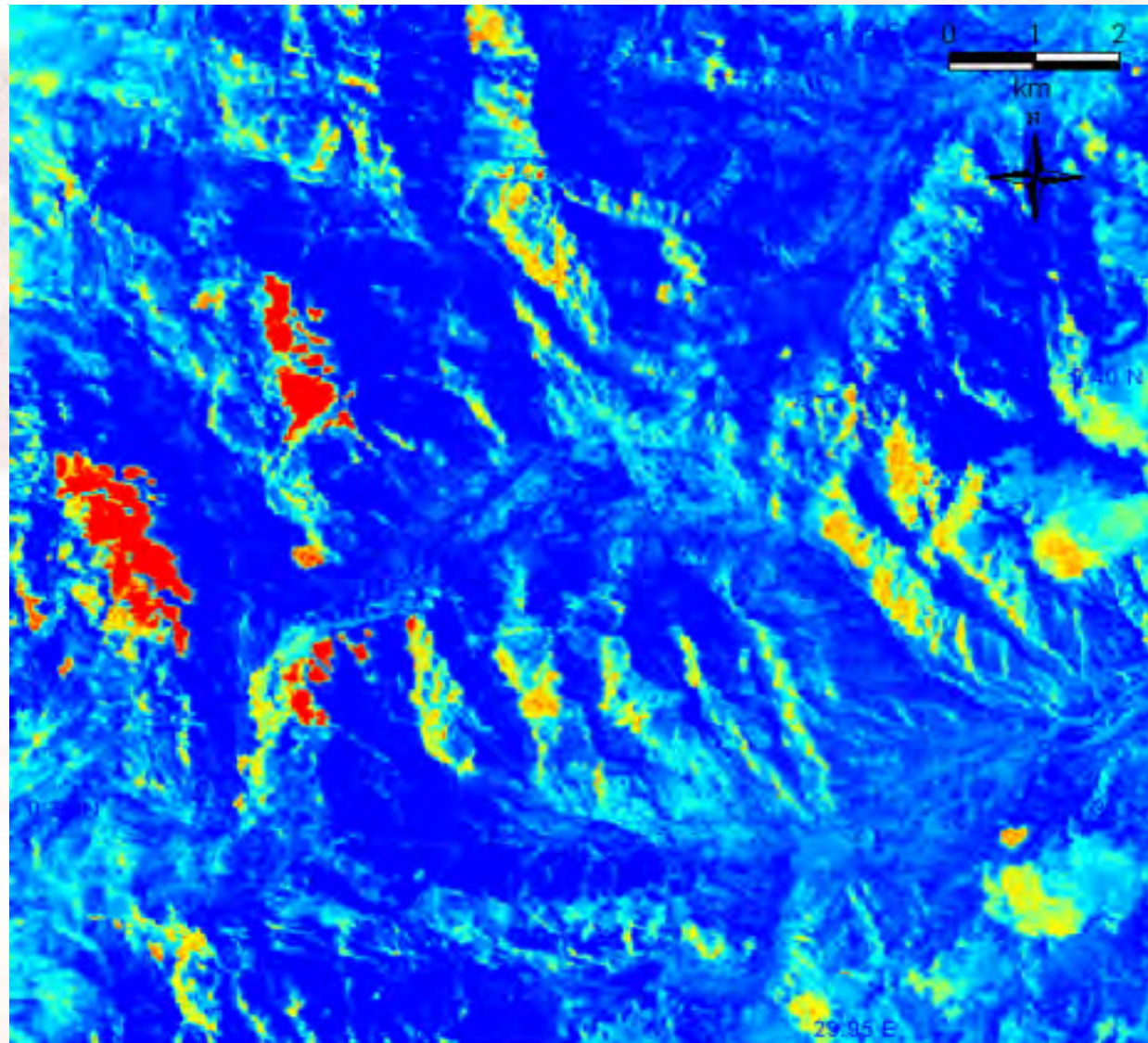

*Normalised
Difference Snow
Index (NDSI)*
 $(\text{Band2} - \text{Band5}) /$
 $(\text{Band2} + \text{Band5})$



TERRA ASTER satellite image acquired 22nd of February 2005

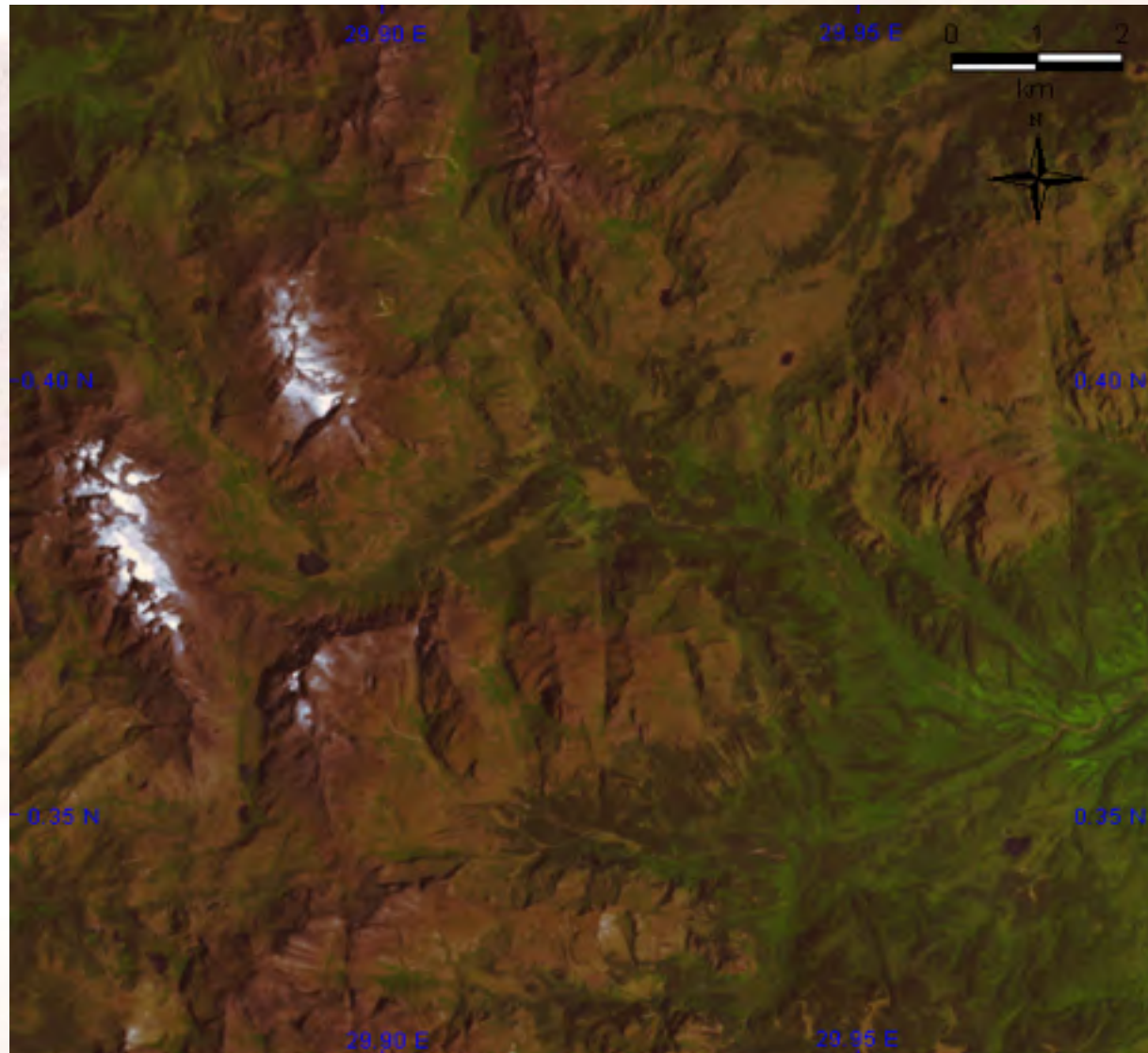

There are no clouds in this image and the glaciers stand out as white, with off-white probably representing newly fallen snow and exposed rock (glacial retreat)





Comparison Landsat TM 1987 and TERRA ASTER 2005

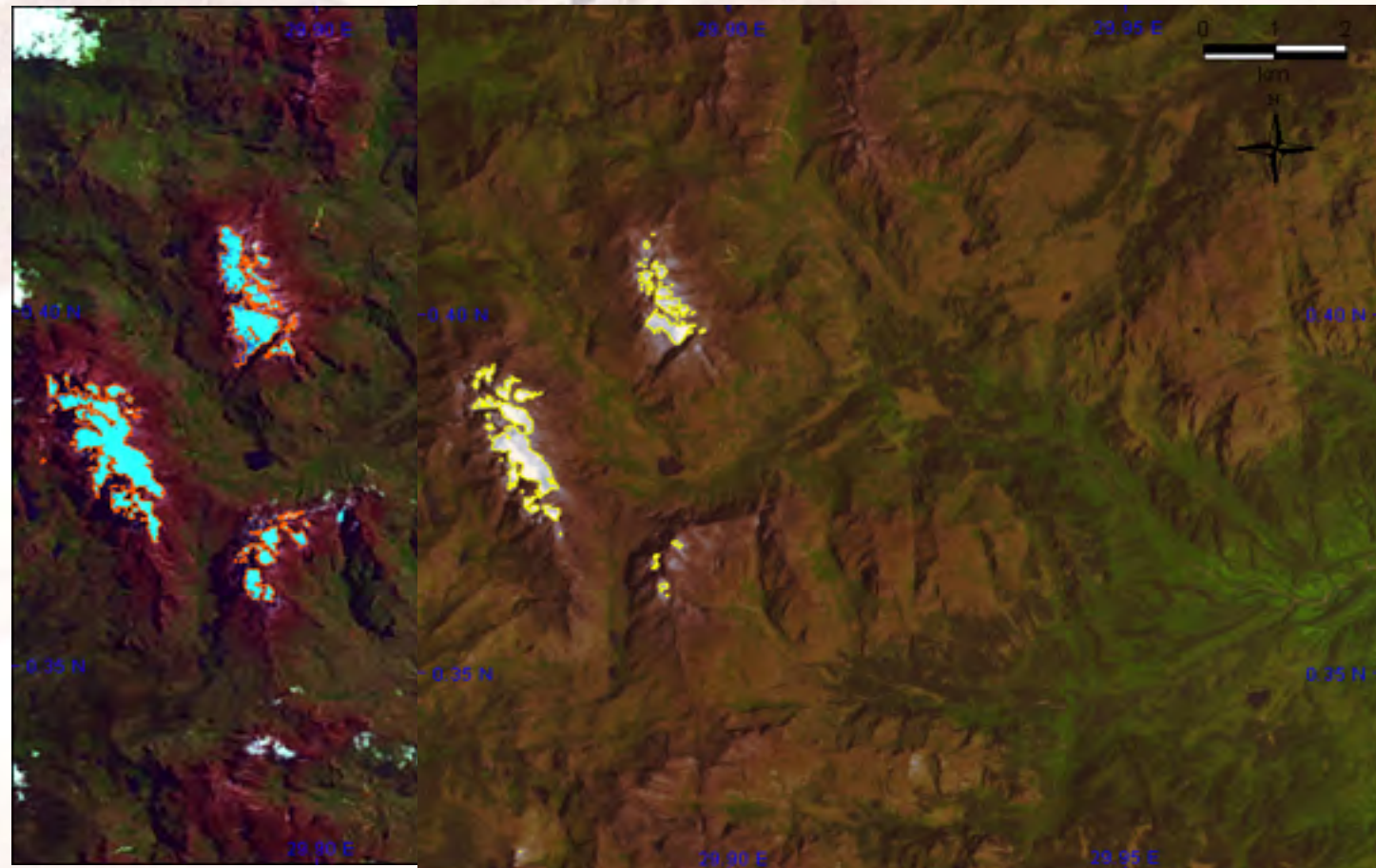

Comparison of extent of the glaciers in 1987 and 2005 interpreted from the backdrop satellite image.





Mountain Rwenzori Glacier Changes 1906-2005

The extent of the glaciers of Mountain Rwenzori 1906, 1987 and 2005.

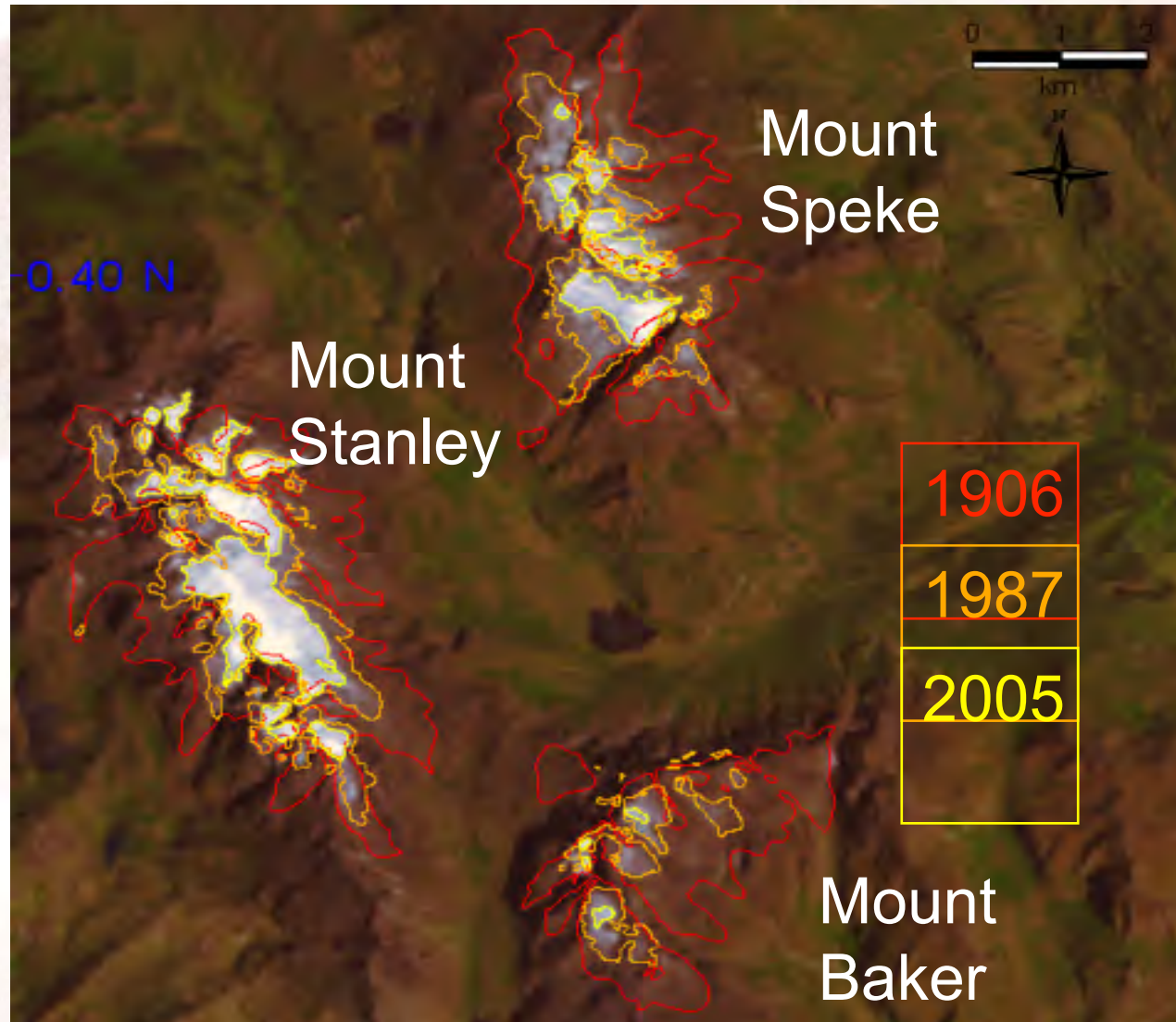



Duke of Abruzzi expedition peak map from 1906

Since 1906 the glaciers of the Rwenzori Mountains have decreased from around 6.5 km² to 1.0 km². If the trend continues the glaciers will disappear in 20 years.

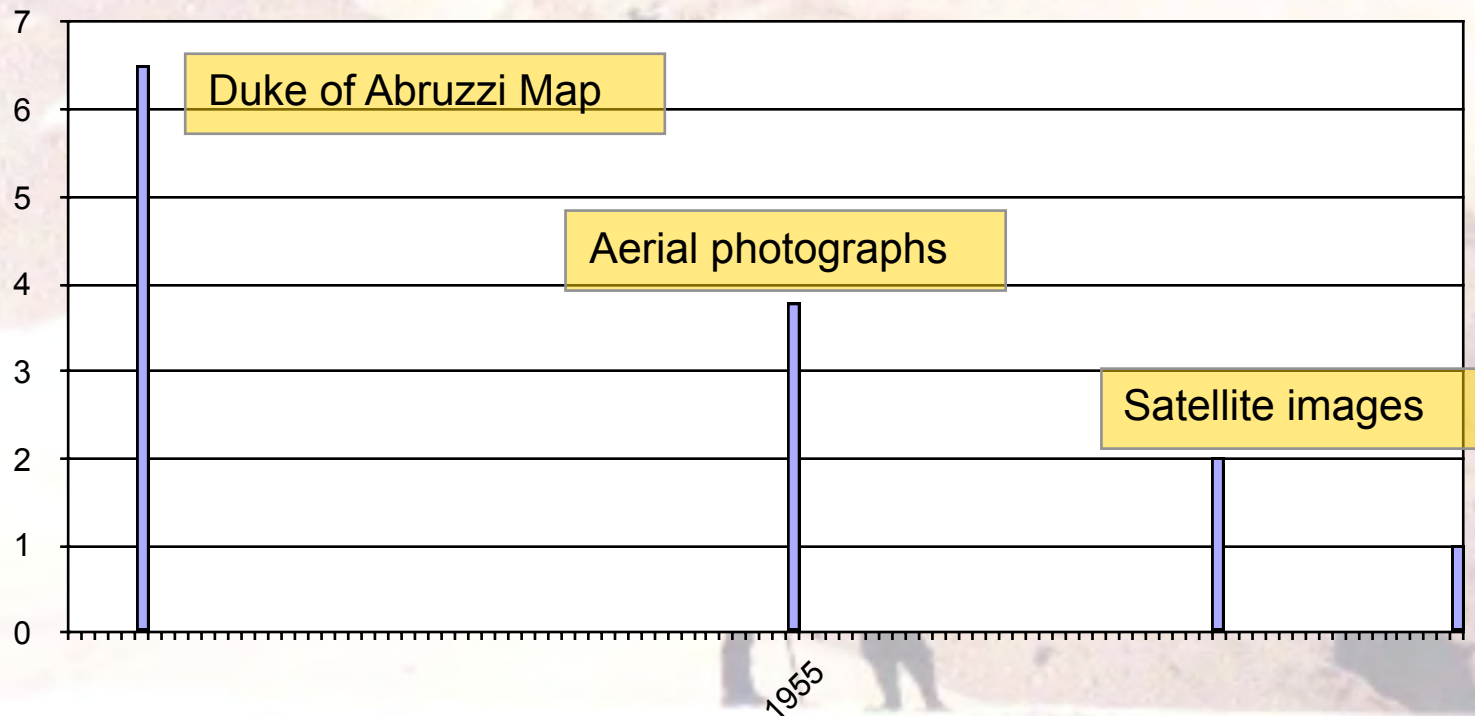



Driving forces contributing to glacier retreat

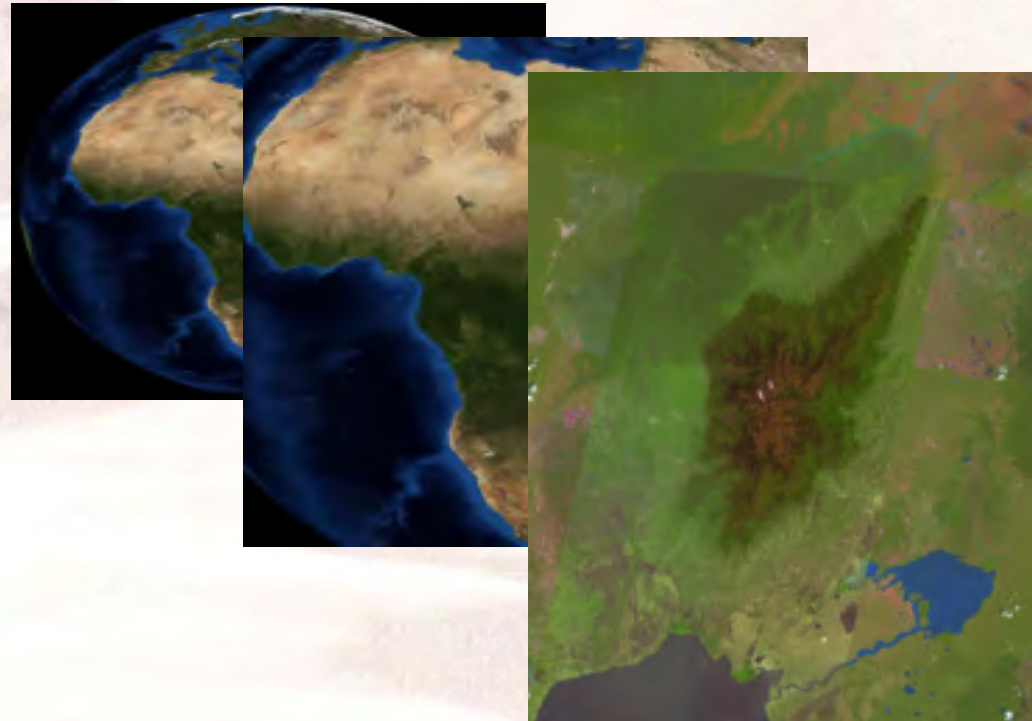

- a) **Global changes in temperature and atmospheric circulation patterns.**
- b) **Continental drying (less precipitation and more sunshine)**
- c) **Local changes in land use and land cover** (documented in other Mountains in East Africa, but not the Rwenzoris)



Driving forces contributing to glacier retreat

Global changes in Temperature

- Significant trends of increasing surface air Temperature
- But glaciers reside at elevations 3 to 4 km higher in the troposphere

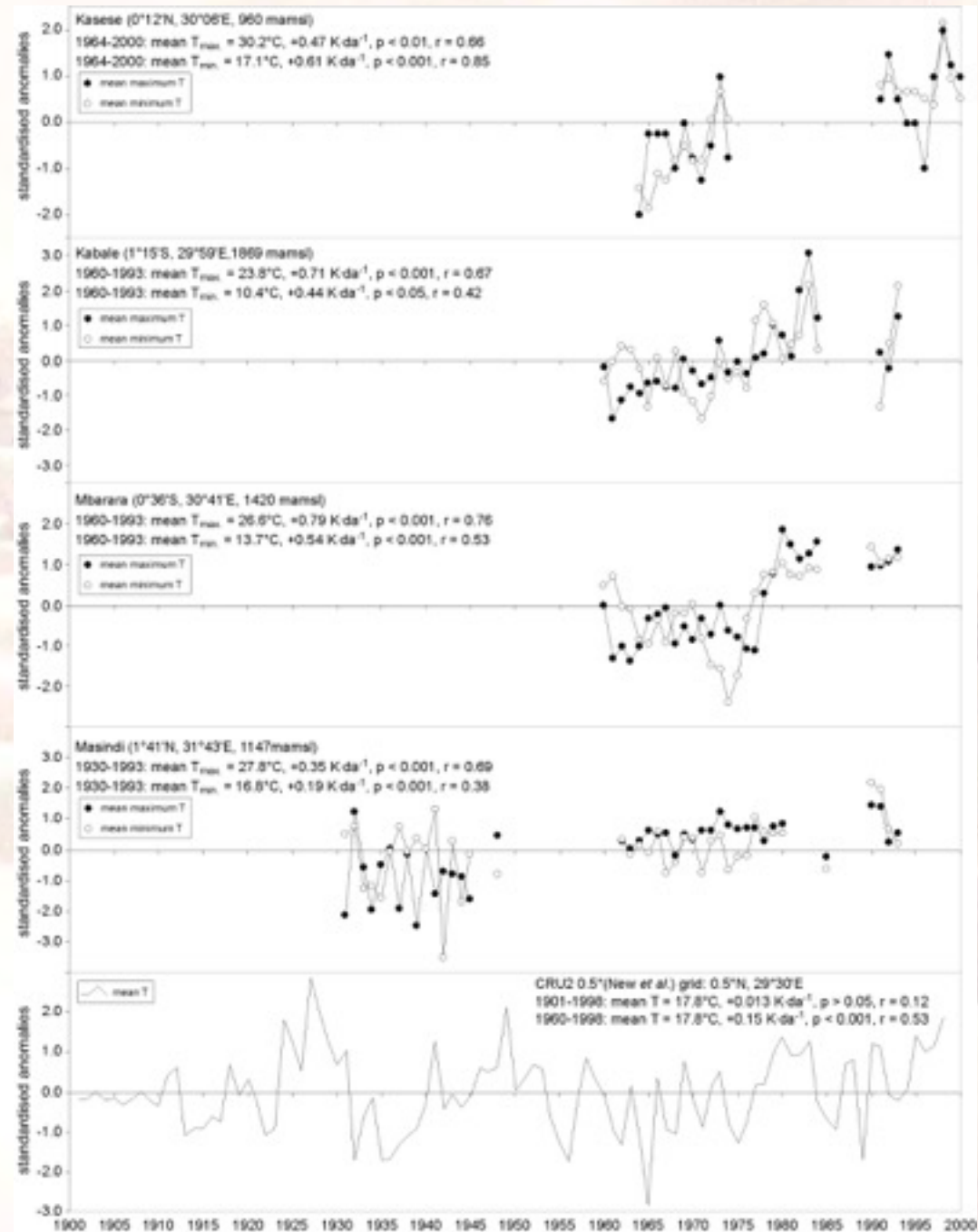



Data are very limited but significant trends of increasing air temp also observed in the troposphere.

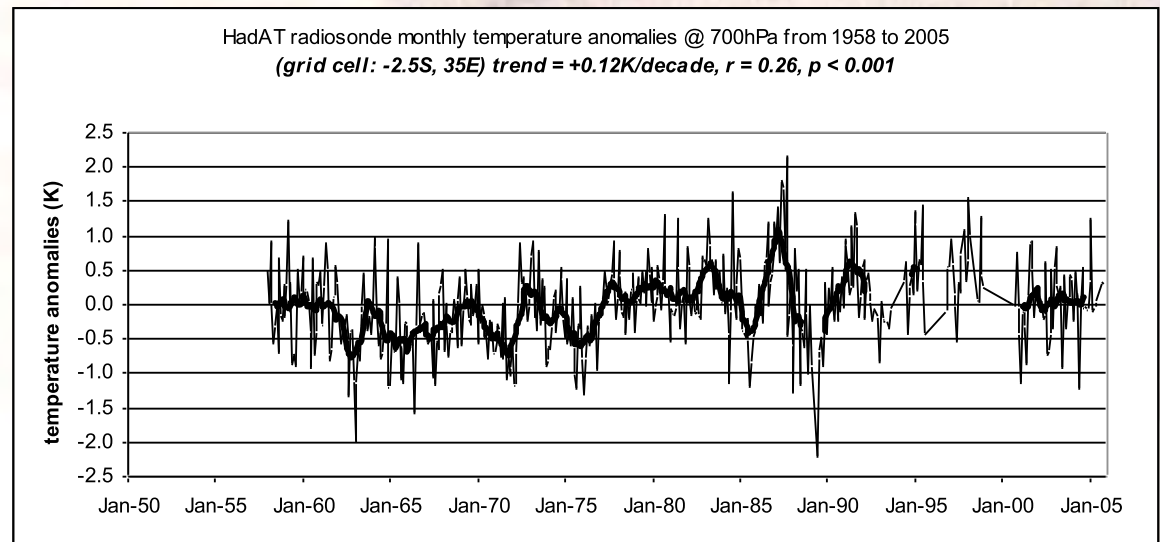
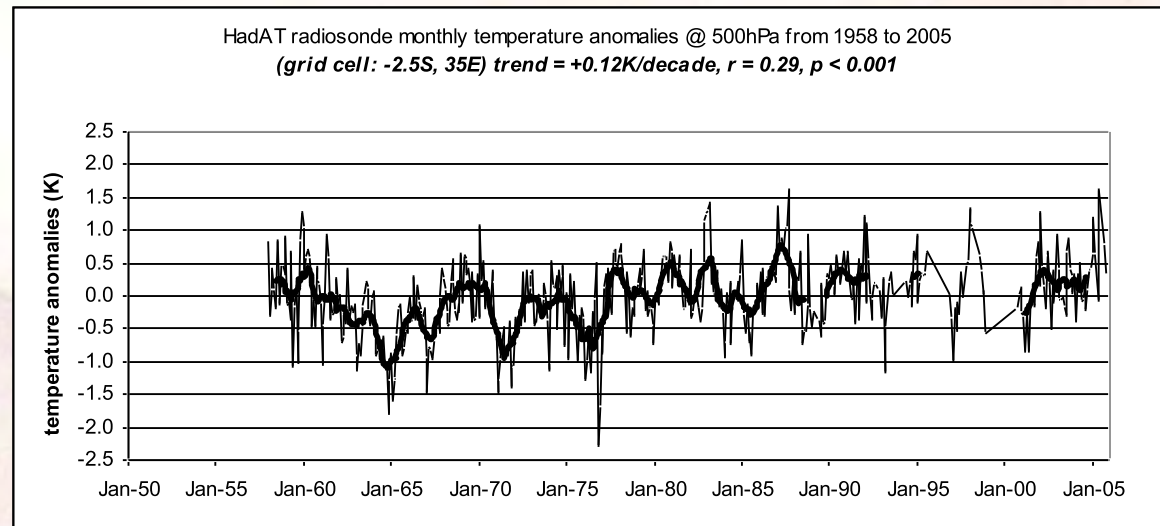



Driving forces contributing to glacier retreat

Continental drying

- no evidence of decreasing humidity in western Uganda from station rainfall records.

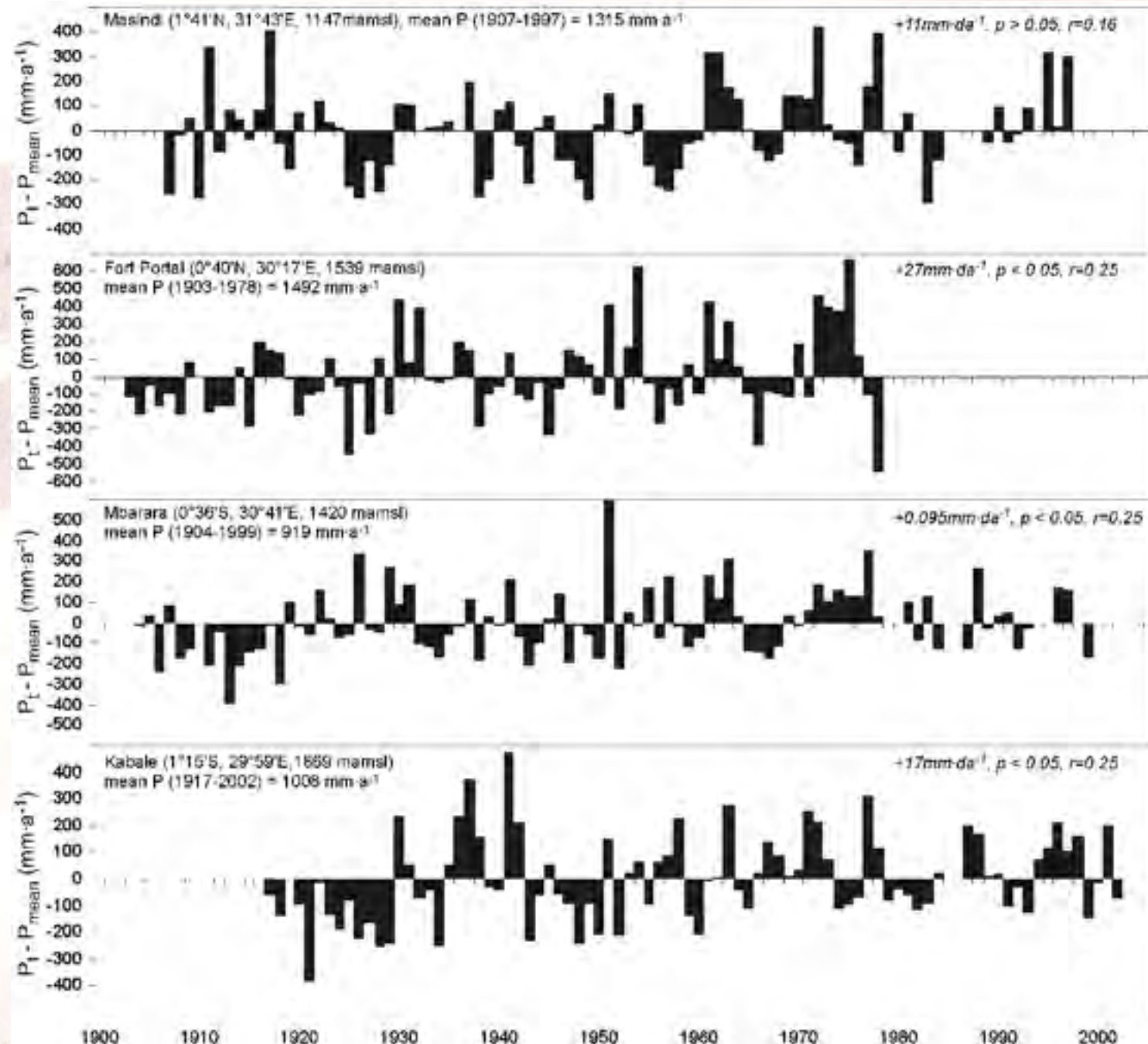



Driving forces contributing to glacier retreat

Continental drying

- no evidence of decreasing humidity in western Uganda from gridded climate datasets (CRU2).

CRU2 annual precipitation from 1901 to 1998

(grid cell: 0.5N, 29.5E), +0.06mm/decade, $r = 0.17$, $p = 0.077$

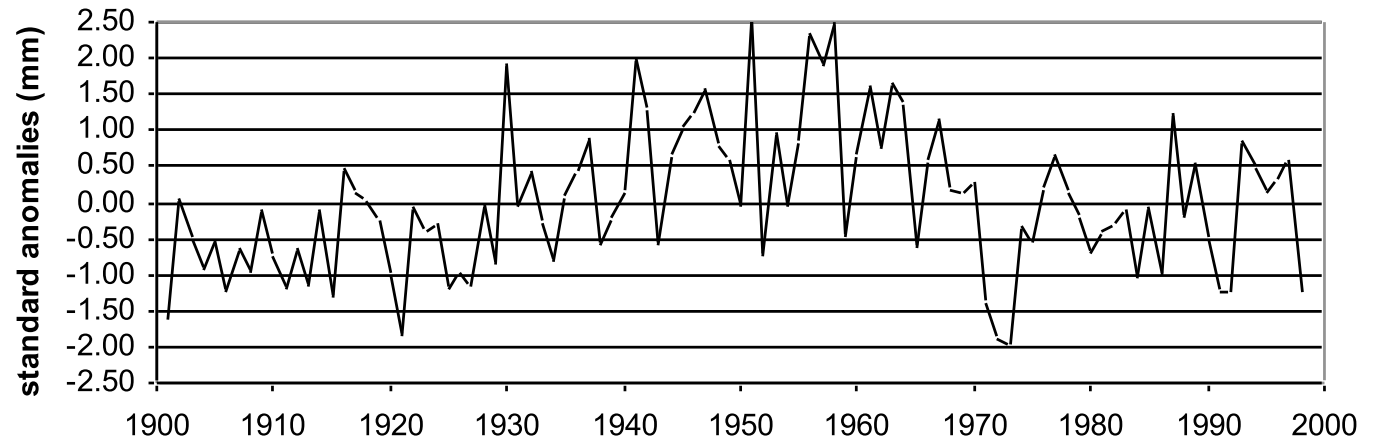

CRU2 anomalies in mean annual vapour pressure from 1901 to 1995

(grid cell: 0.5N, 29.5E), $r=0.099$, $p=0.34$

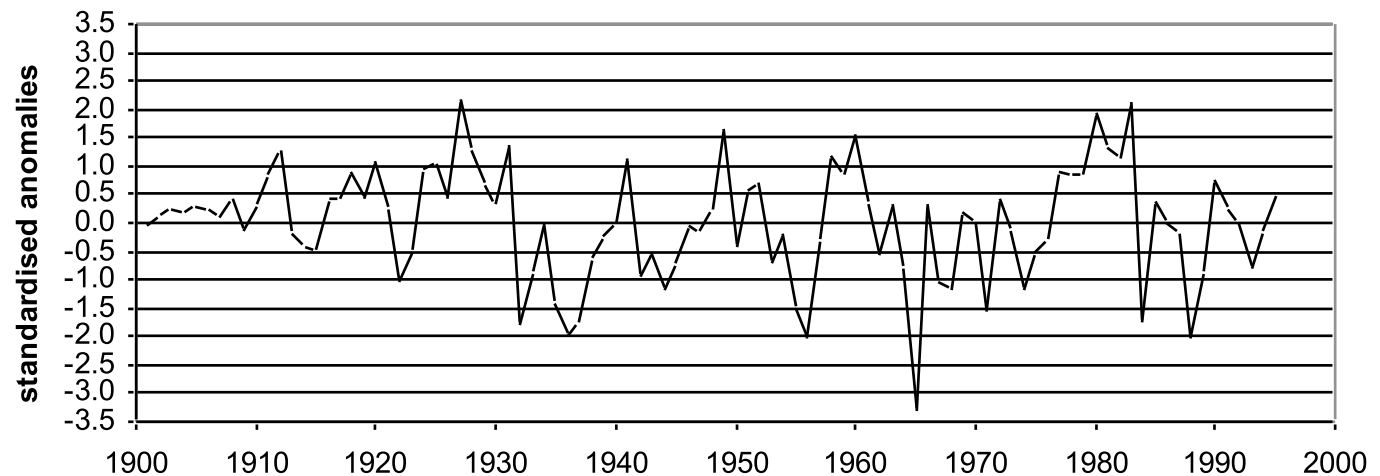



Driving forces contributing to glacier retreat

Local changes in land use and land cover

Population growth (3% yr)



Agricultural activity (incl. slash&burn)



Reduction of vegetation growth



Drying out of local atmosphere



Less precipitation and more sunshine



Negative mass balance of ice and snow



Retreat of glaciers

Landcover and vegetation (Africover and National Biomass project)

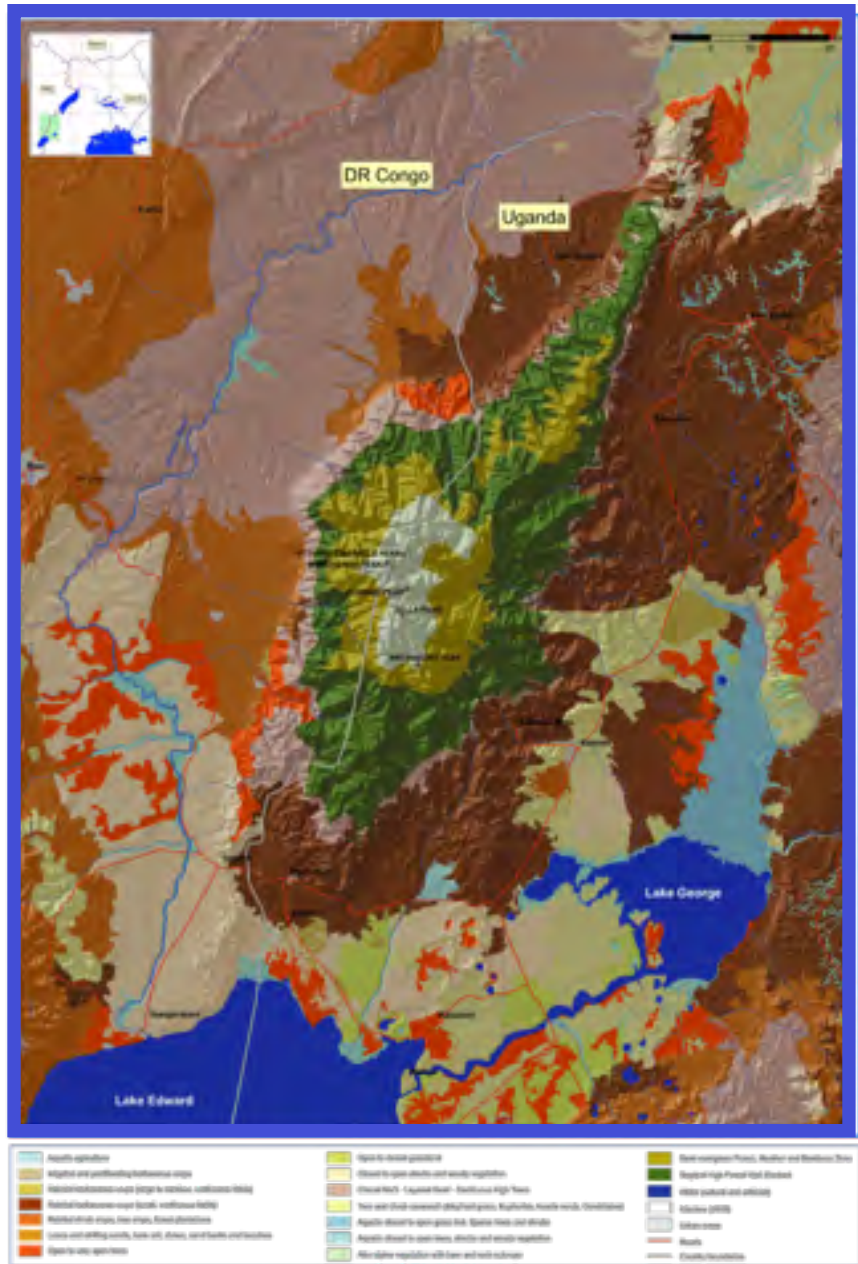



Protected Areas (PA)





Rwenzori 1906-2006

Landcover changes in the Rwenzori Mountains: the glaciers retreat

Ag + PA





Population distribution (Landsat 2002)





Field data collection June 2006 – 100 years after the Abruzzi expedition

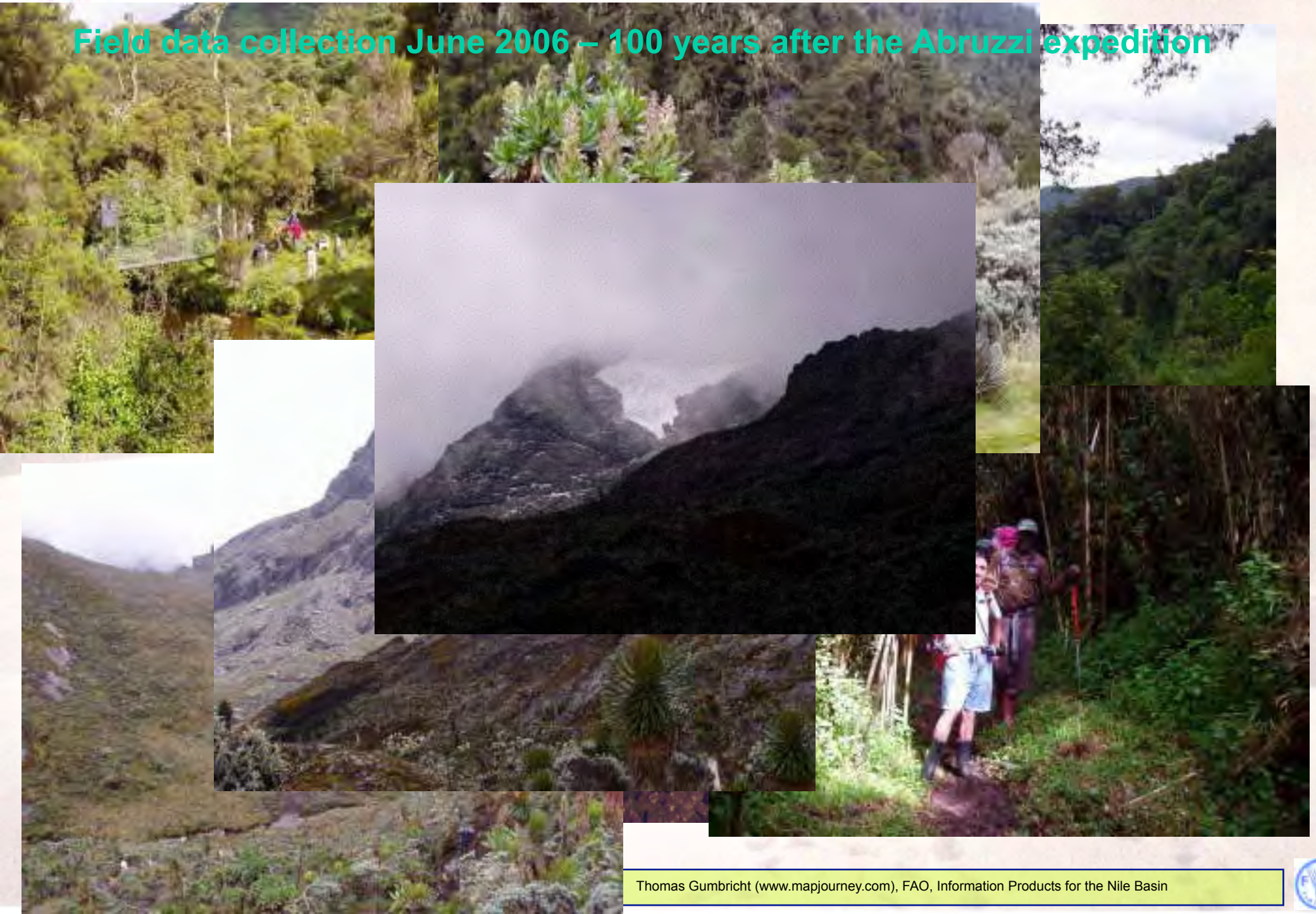



Landcover mapping from ASTER data – a first attempt

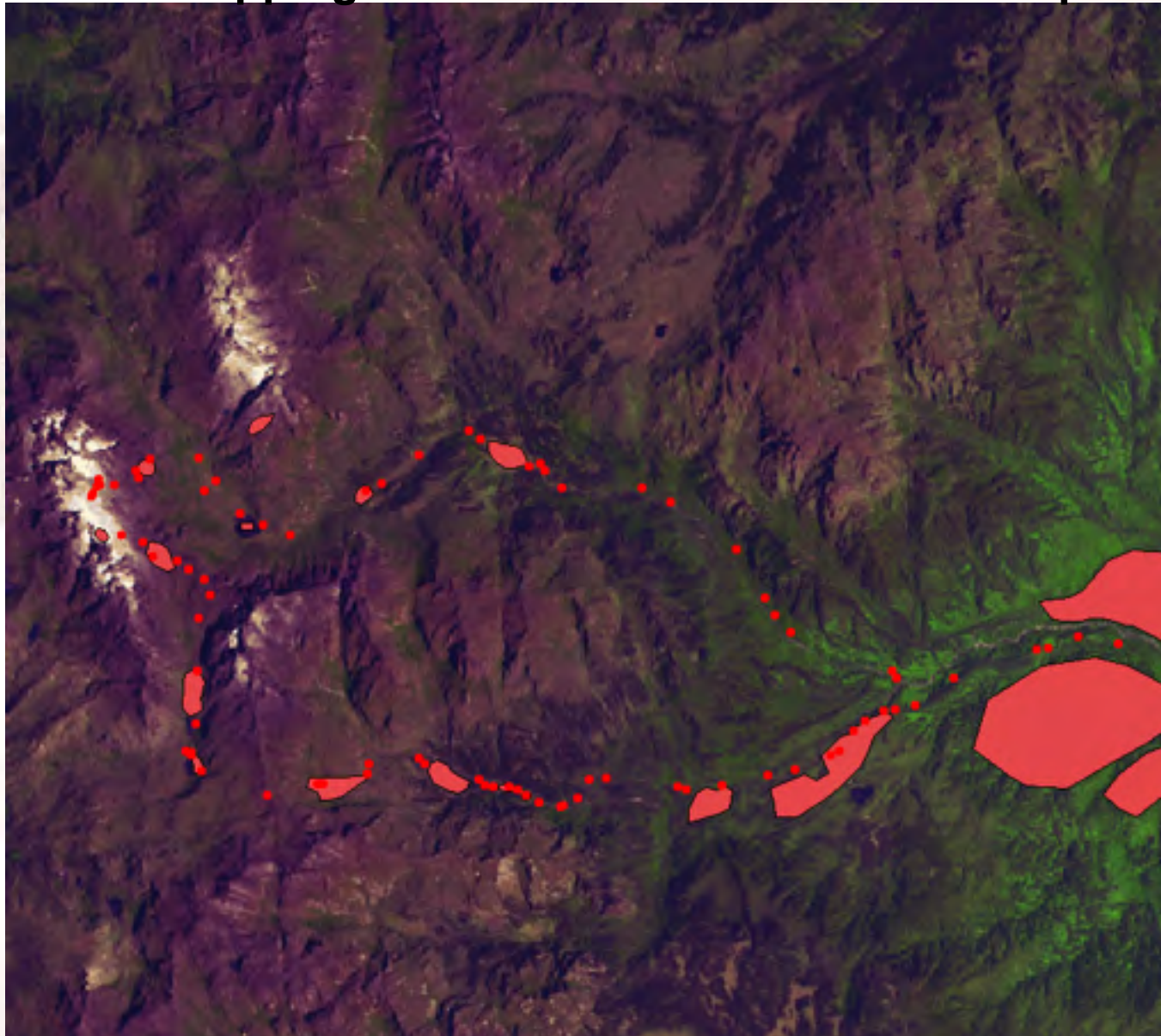



Landcover changes - high resolution satellite imagery 1973-2005

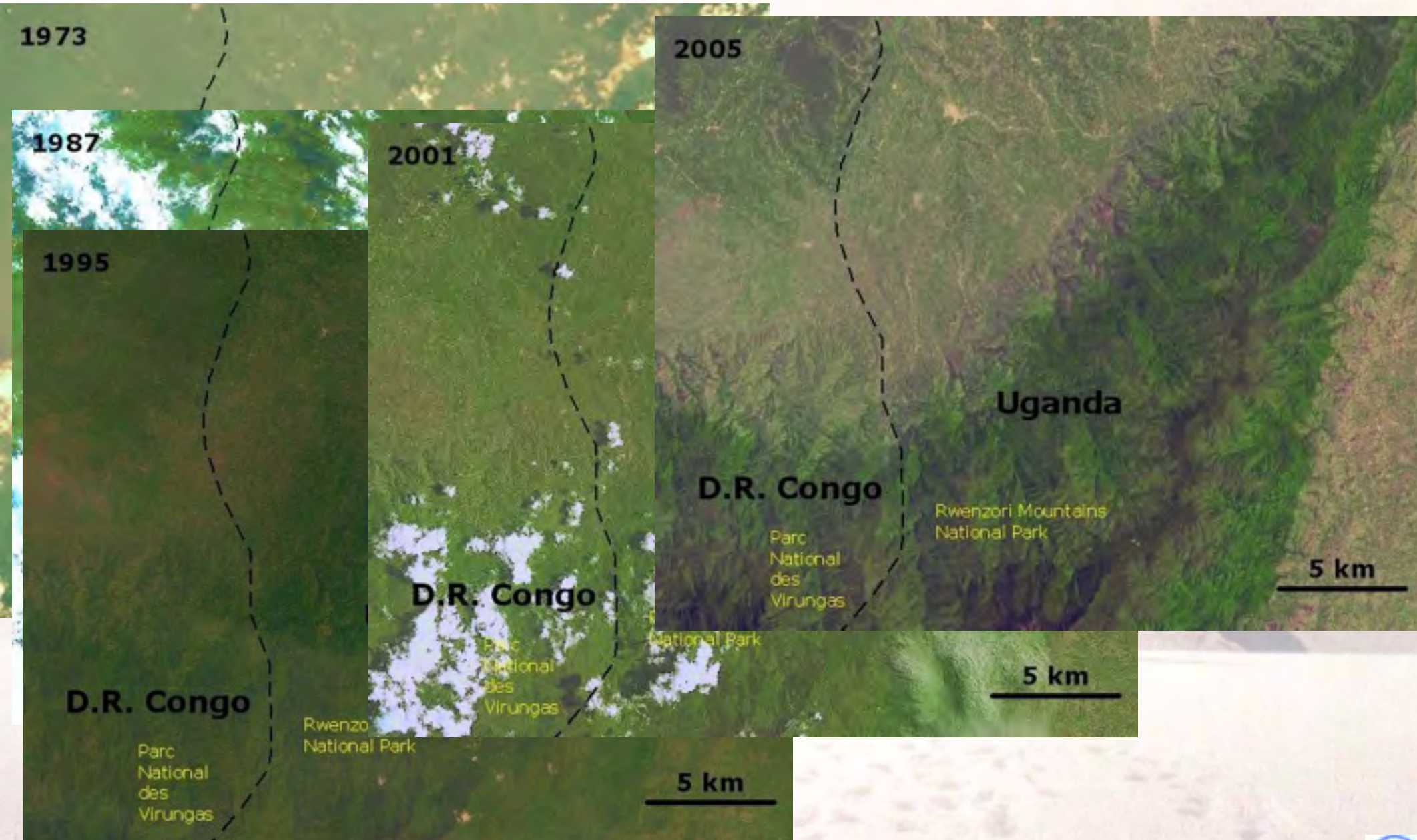



Landcover changes – Adjusted NDVI trend 1973-2005

Landsat MSS

Path 185: row 60: date 19730204

Path 186: row 60: date 19730205

Path 186: row 60: date 19750312

Landsat TM

Path 173: row 060: date 19870807

Path 173: row 060: date 19950117

Landsat ETM

Path 173: row 059: date 20010109

Path 173: row 060: date 20010314

Path 173: row 060: date 20011211

Path 173: row 060: date 20030131

ASTER

AST_L1B_00302212005083011_02282005091034

AST_L1B_00302212005083003_02282005090940

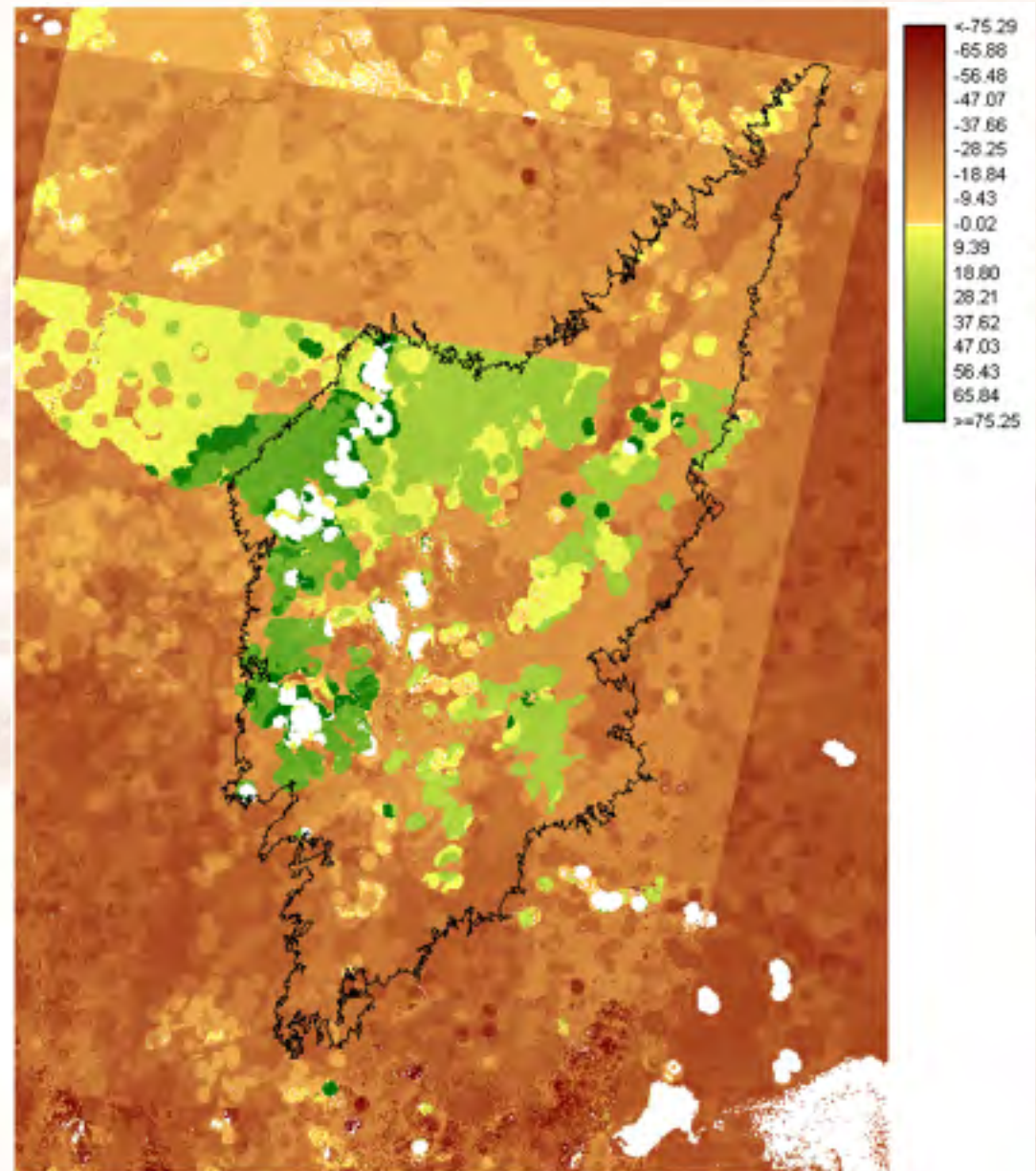

SPOT Program

Jonas



1E1630
Remote Sensing
2005

Overview
Orbits
Satellites
Landsat
SPOT
Other ERS
Meteorological
Oceanic
Others



SPOT Program

SPOT (Système Pour l'Observation de la Terre) is a French program, with some participation from Sweden and Belgium (Sweden contributes with 4% and the receiving station in Kiruna, a very good location for polar-orbiting satellites!)

SPOT-1 was launched in 1986 and was the first earth resource satellite to implement a linear sensor array and the pushbroom technique.

It was also the first system to have pointable optics, enabling side-to-side off-nadir viewing capabilities and thus stereoscopic imaging.

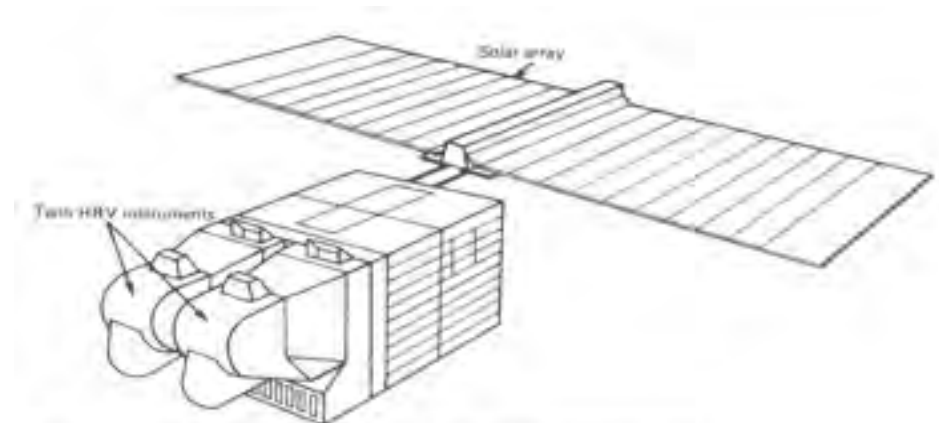

Figure 6.22 SPOT observation configuration. (Adapted from CNRS/ESRIS)

Jonas



1E1630
Remote Sensing
2005

Overview
Orbits
Satellites
Landsat
SPOT
Other ERS
Meteorological
Oceanic
Others

SPOT Generations

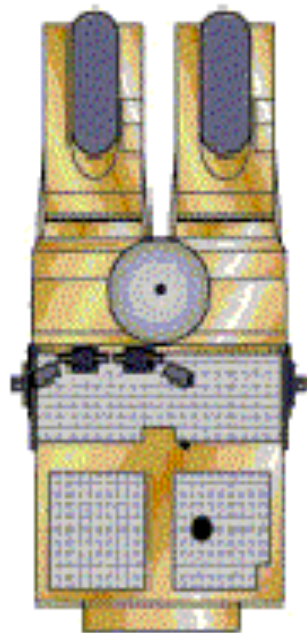

Spot 1, 2, 3

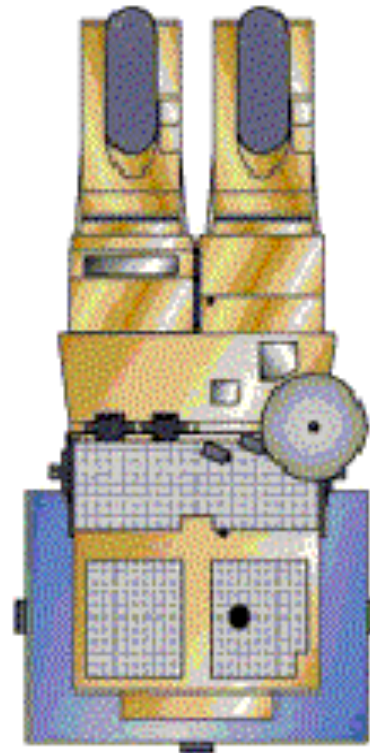

Spot 4

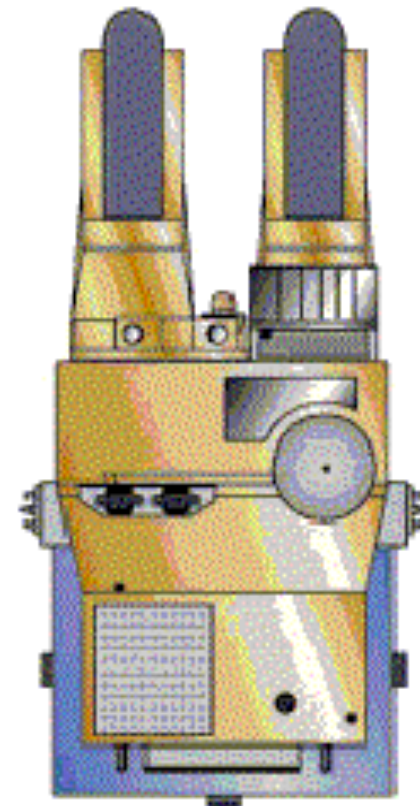

Spot 5



Jonas



1E1630
Remote Sensing
2005

- Overview
- Orbits
- Satellites
- Landsat
- SPOT**
- Other ERS
- Meteorological
- Oceanic
- Others

SPOT Satellite Generations

Satellite	Launch	Dead	Pan bands	MSS (XS) bands	Vegetation bands	Orbit
SPOT-1	Feb 21, 1986	Dec 31, 1990	1 (6 bit) 10 m	1-3 (8 bit) 20 m		26 days 832 km
SPOT-2	Jan 21, 1990		1 (6 bit) 10 m	1-3 (8 bit) 20 m		26 days 832 km
SPOT-3	Sep 25, 1993	Nov 14, 1996	1 (6 bit) 10 m	1-3 (8 bit) 20 m		26 days 832 km
SPOT-4	Mar 23, 1998		Red 10 m	G, NIR, MIR 20 m	4 1000 m	26 days 832 km
SPOT-5	May 3, 2002		2 2,5-10 m	B1-B3 10 m B4 20 m	4 1000 m	26 days 832 km

Each orbit takes about 101 minutes.

Jonas



1E1630
Remote Sensing
2005

Overview
Orbits
Satellites
Landsat
SPOT
Other ERS
Meteorological
Oceanic
Others

SPOT 1-3 Satellite Sensors

Two identical **HRV (High Resolution Visible)** sensors

- Linear array detector
- Pointable optics (+/- 27°)
 - improves revisit time
 - stereo imaging capabilities
- Field-of-View angle: 4.13°
- Swath width of 60 km (nadir) to 80 km (27° off-nadir)

The HRVs can register in either Pan or MS mode

Panchromatic mode 6 bit (64 levels)

6000 detector array → 10 m spatial resolution

0.51 - 0.73 μm

Multispectral mode 8 bit (256 levels each)

3 x 3000 detector arrays → 20 m spatial resolution

0.50 - 0.59 μm (Green)

0.61 - 0.68 μm (Red)

0.79 - 0.89 μm (Near IR)

Jonas



1E1630
Remote Sensing
2005

Overview
Orbits
Satellites
Landsat
SPOT
Other ERS
Meteorological
Oceanic
Others

SPOT 1-3 HRV Sensors

The Angular Field of View is constant, 4.13° , so the swath width varies with the off-nadir angle, from 60 km at nadir, to 80 km.

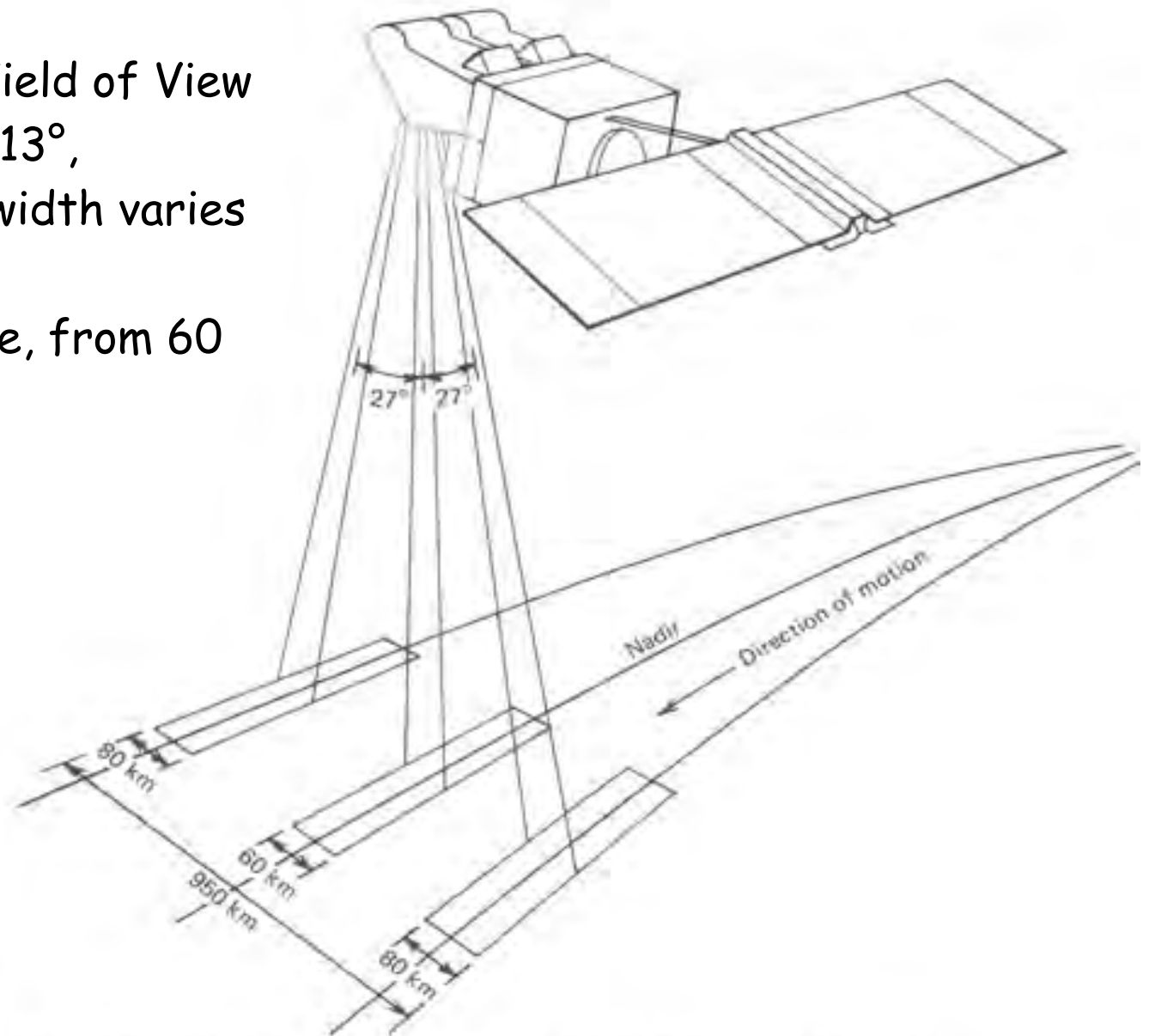

Figure 6.23 SPOT off-nadir viewing range. (Adapted from CNES diagram.)

Jonas



1E1630
Remote Sensing
2005

Overview
Orbits
Satellites
Landsat
SPOT
Other ERS
Meteorological
Oceanic
Others

SPOT 1-3 HRV Sensors

With the two HRV sensors set to overlap each other, SPOT will have an effective swath width of 117 km.

Each HRV is capable of collecting pan and MS data simultaneously, resulting in four data streams. However, only two can be transmitted simultaneously.

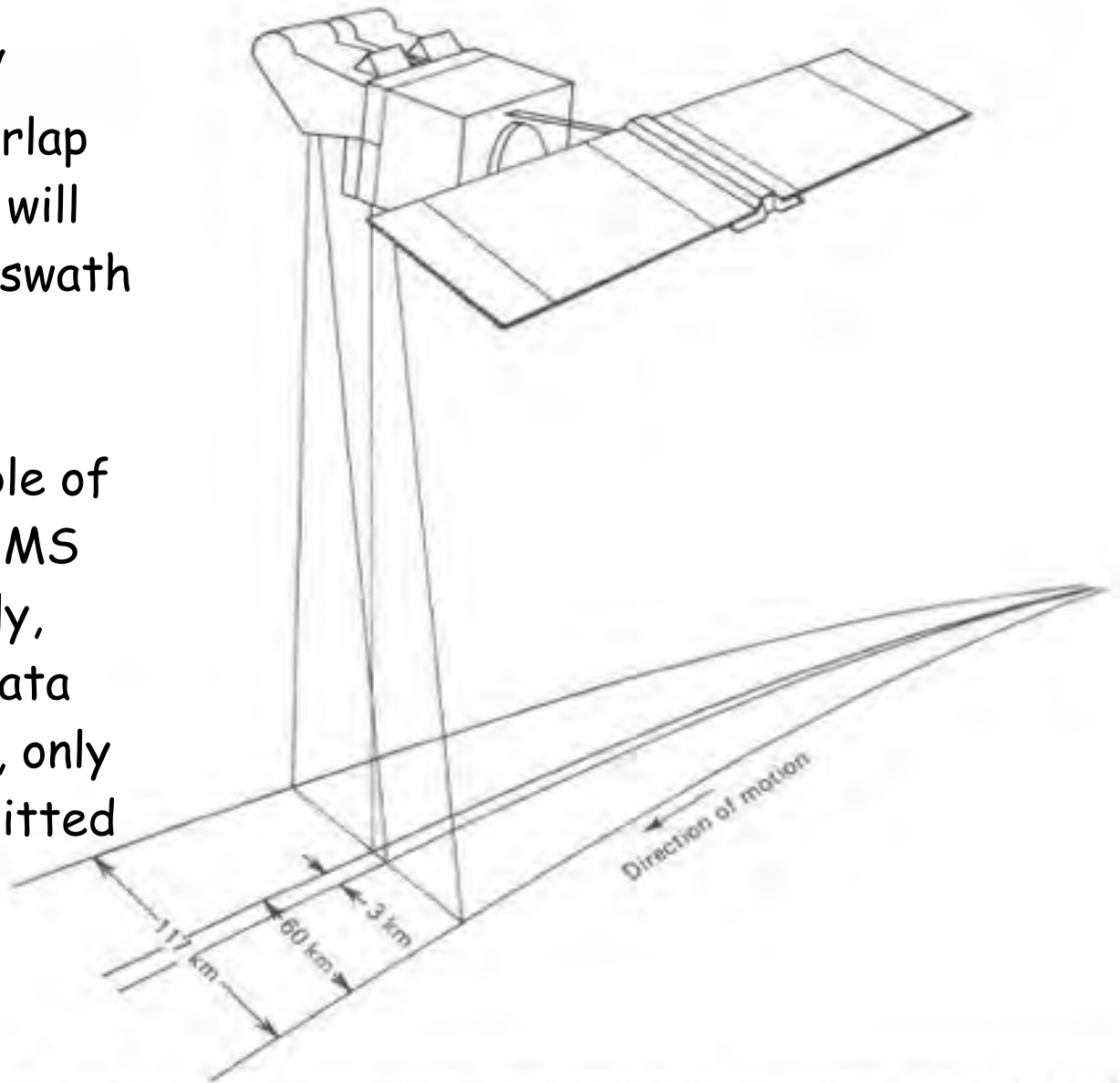

Figure 6.24 SPOT ground coverage with HRVs recording adjacent swaths. (Adapted from CNES diagram.)

Jonas



1E1630
Remote Sensing
2005

Overview
Orbits
Satellites
Landsat
SPOT
Other ERS
Meteorological
Oceanic
Others

SPOT 4 Satellite Sensors

Two identical HRVIR (High Resolution Visible and IR) sensors

The HRVIRs can register in either Pan (Red) or MS mode

"Panchromatic" mode

8 bit (256 levels)

6000 detector array → 10 m spatial resolution

+ 0.61 - 0.68 μm (Red)

Multispectral mode

8 bit (256 levels each)

4 x 3000 detector arrays → 20 m spatial resolution

0.50 - 0.59 μm (Green)

0.61 - 0.68 μm (Red)

0.79 - 0.89 μm (Near IR)

+ 1.58 - 1.75 μm (Mid IR)

Vegetation instrument (for frequent, large-area monitoring)

+ 0.43 - 0.47 μm (Blue) 1000 m

+ 0.61 - 0.68 μm (Red) 1000 m

Jonas



1E1630
Remote Sensing
2005

Overview
Orbits
Satellites
Landsat
SPOT
Other ERS
Meteorological
Oceanic
Others

SPOT 5 Satellite Sensors

Two identical HRG (High Resolution Geometric) sensors

+	0.48 - 0.71 μm (Visible)	2.5 (5) m spatial resolution
+	0.50 - 0.59 μm (Green)	10 m
+	0.61 - 0.68 μm (Red)	10 m
+	0.79 - 0.89 μm (Near IR)	10 m
	1.58 - 1.75 μm (Mid IR)	20 m

One HRS (High Resolution Stereoscopic) instrument

+	0.49 - 0.69 μm (Visible)	5/10 m spatial resolution
---	-------------------------------------	---------------------------

Vegetation 2 instrument (for frequent, large-area monitoring)

(+)	0.45 - 0.52 μm (Blue)	1000 m
	0.61 - 0.68 μm (Red)	1000 m
	0.79 - 0.89 μm (Near IR)	1000 m
	1.58 - 1.75 μm (Mid IR)	1000 m

Jonas



1E1630
Remote Sensing
2005

Overview
Orbits
Satellites
Landsat
SPOT
Other ERS
Meteorological
Oceanic
Others

SPOT HRG across-track stereo

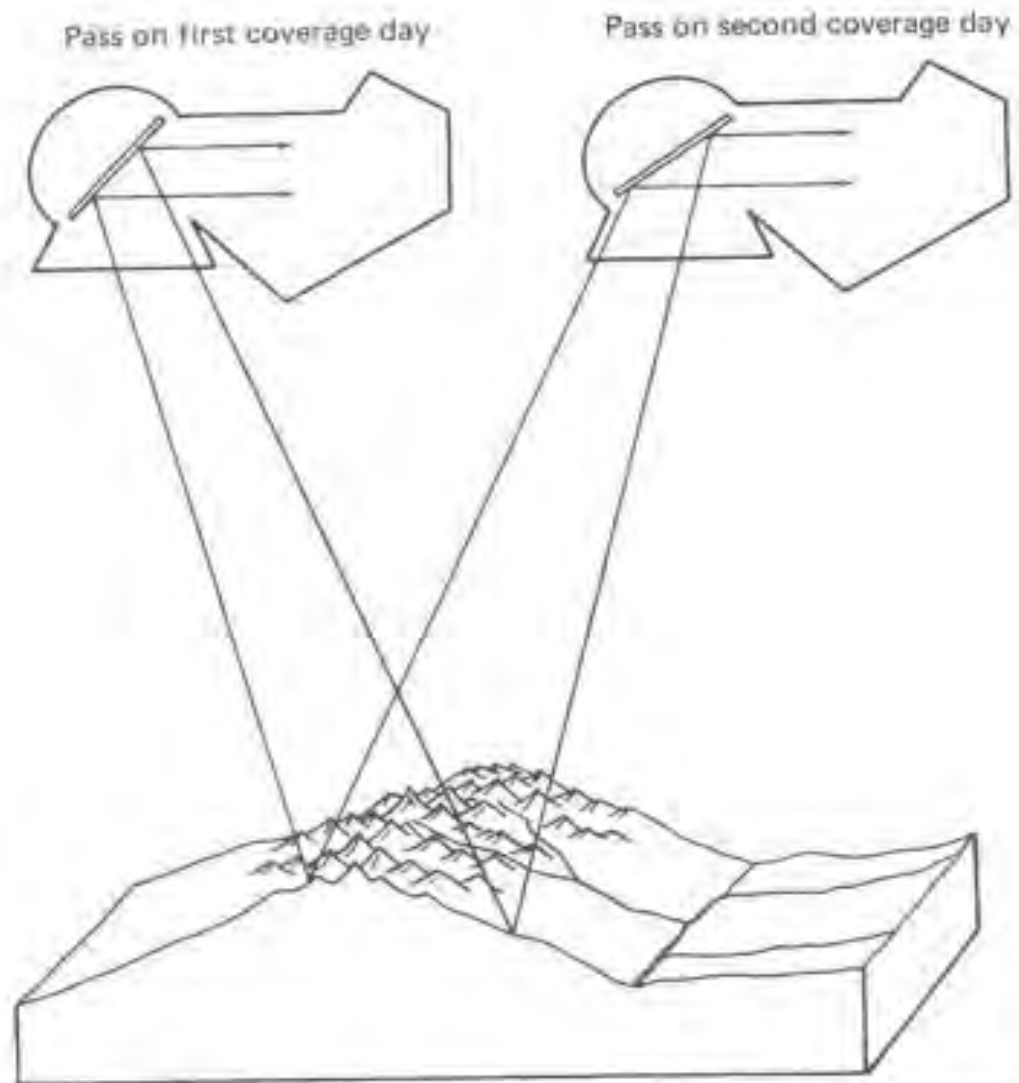

Figure 6.25 SPOT stereoscopic imaging capability. (Adapted from CNES diagram.)

Jonas



1E1630
Remote Sensing
2005

- Overview
- Orbits
- Satellites
- Landsat
- SPOT**
- Other ERS
- Meteorological
- Oceanic
- Others

SPOT 5 HRS along-track stereo

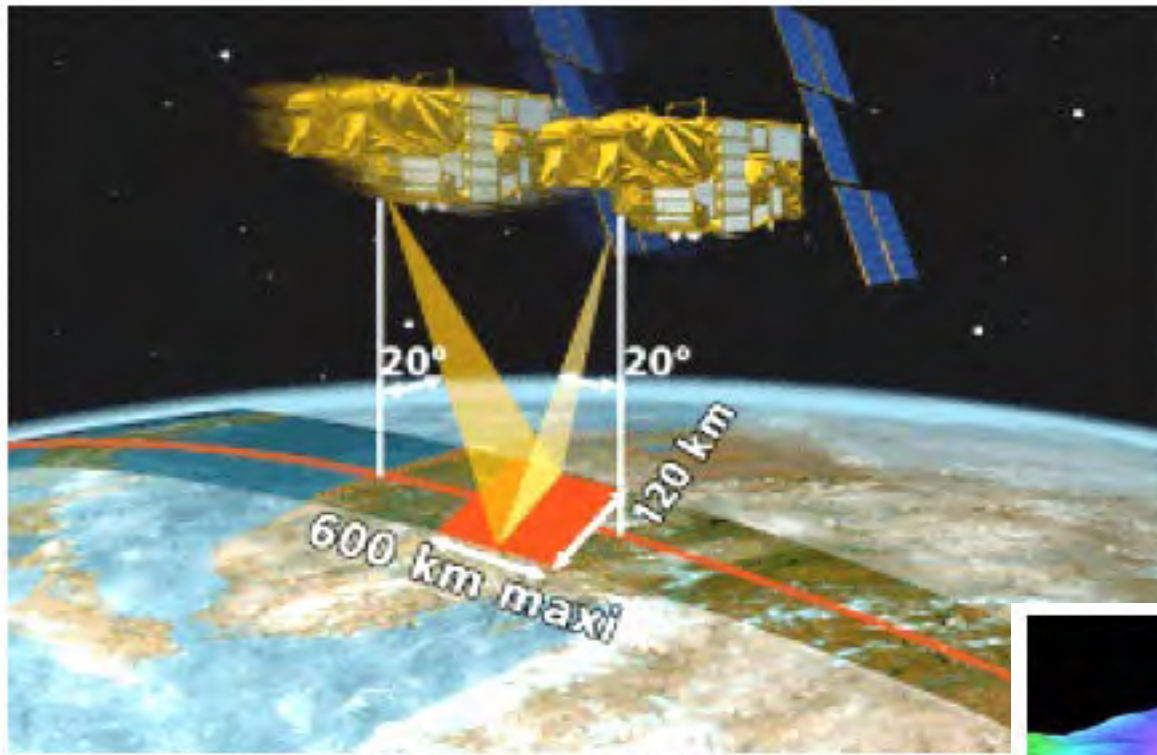
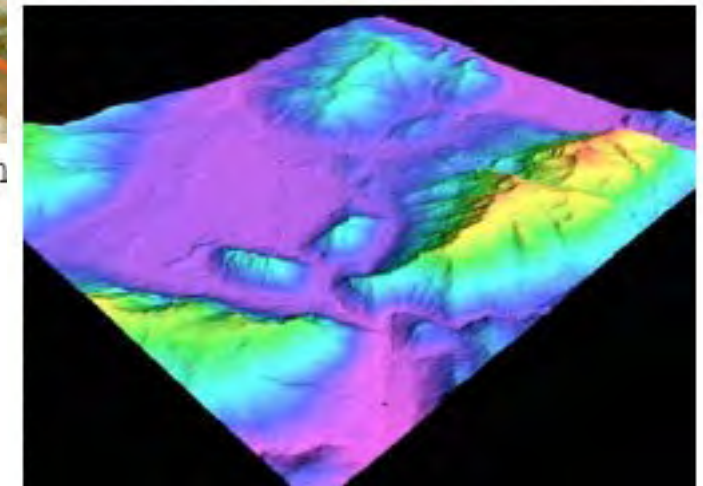

Figure 1. SPOT-5/HRS along-track image acquisition (Source: CNES).



DEM from SPOT HRS

Jonas



1E1630
Remote Sensing
2005

- Overview
- Orbits
- Satellites
- Landsat
- SPOT**
- Other ERS
- Meteorological
- Oceanic
- Others

SPOT Revisit Pattern

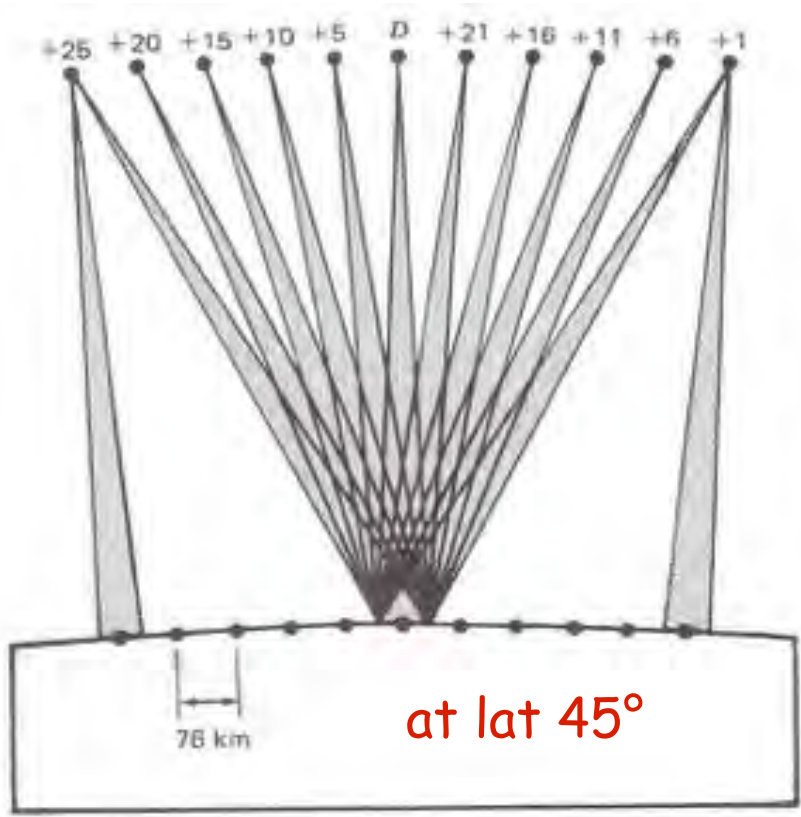

(a)

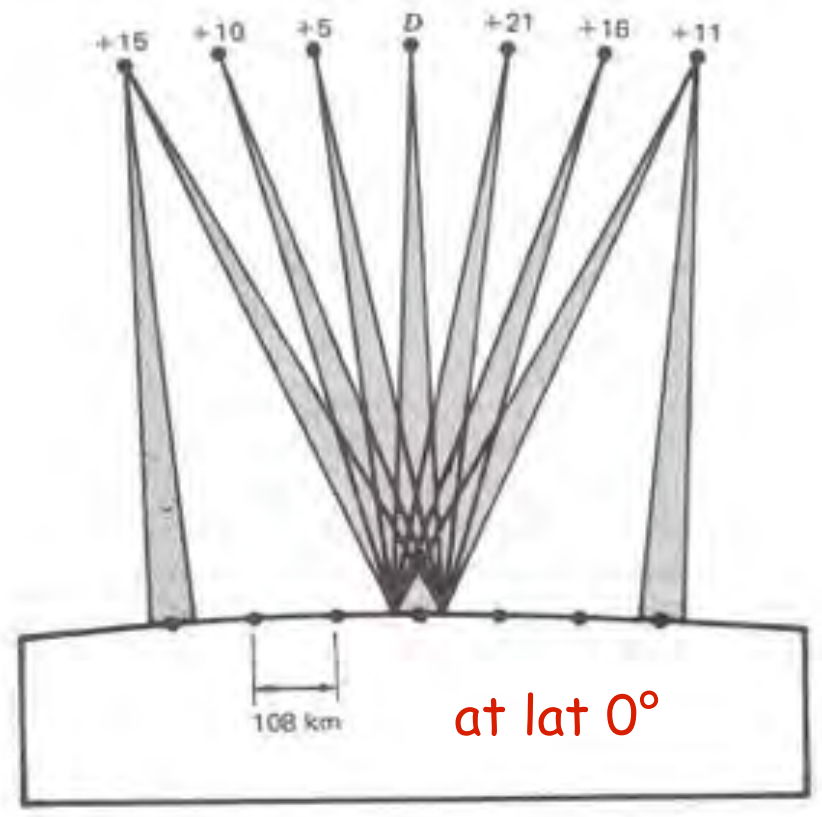

(b)

Figure 6.21 SPOT revisit pattern: (a) latitude 45°; (b) latitude 0°. (Adapted from CNES diagram.)

Jonas



1E1630
Remote Sensing
2005

- Overview
- Orbits
- Satellites
- Landsat
- SPOT**
- Other ERS
- Meteorological
- Oceanic
- Others

Datamodeller i GIS



IRS - Indian Remote Sensing



IRS-P5



IRS-1A

Jonas



1E1630
Remote Sensing
2005

- Overview
- Orbits
- Satellites
- Landsat
- SPOT
- Other ERS**
- Meteorological
- Oceanic
- Others

IRS - Indian Remote Sensing

Satellite	Launch	Dead	Pan bands	MSS bands	MSS bands	Orbit
IRS-1A	March 1988	1992		LISS-I 4 72.5 m	LISS-II 4 36.25 m	22 days 904 km
IRS-1B	Aug 1991	1999		LISS-I 4 72.5 m	LISS-II 4 36.25 m	22 days 904 km
IRS-1C	Dec 1995		1 5,8 m	LISS-III 4 23,5 / 70,5 m	WiFS 1 188 m	3-24 days 817 km
IRS-1D	Sep 1997		1 5,8 m	LISS-III 4 23,5	WiFS 1 188 m	3-24 days 817 km
P2-P4 (OceanSat)	1994- 1999					
IRS-P6 (ResourceSat)	Oct 2003		Any 5,8 m	LISS-IV 3 5,8 m	AWiFS 4 56-70 m	5-24 days 817 km
IRS-P5 (CartoSat)	May 2005		2 (stereo) 2,5 m			5-126 days 618 km

Jonas



1E1630
Remote Sensing
2005

Overview
Orbits
Satellites
Landsat
SPOT
Other ERS
Meteorological
Oceanic
Others

There are also planned IRS-2 and IRS-3 series

IRS-P6 (ResourceSat)

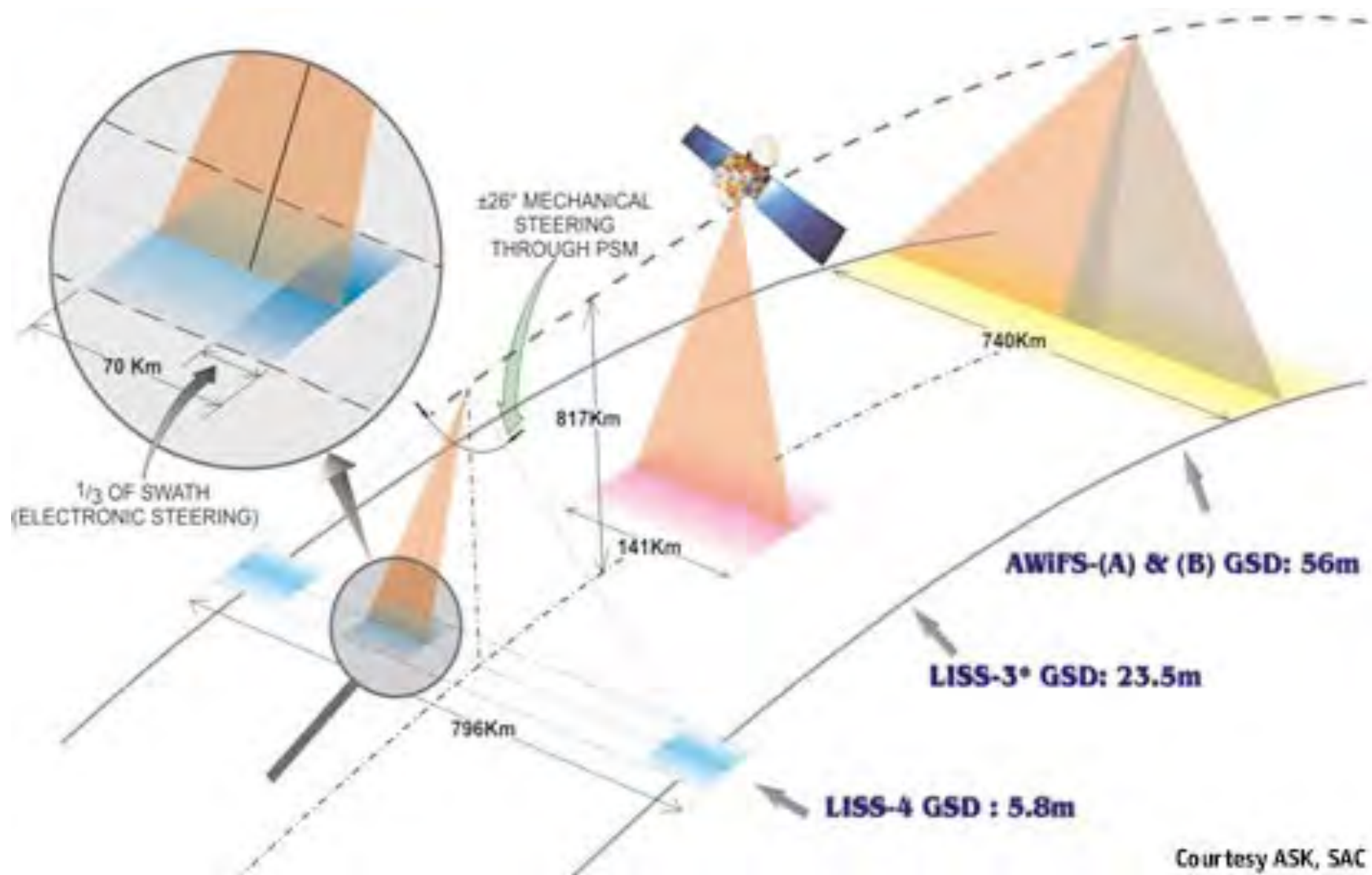

Jonas



1E1630
Remote Sensing
2005

- Overview
- Orbits
- Satellites
- Landsat
- SPOT
- Other ERS**
- Meteorological
- Oceanic
- Others

IRS-P5 (CartoSat)

Launched: May, 2005

2.5 m PAN (0.50-0.85 μm)
+26° forward, -5° aft (stereo)

Orbit period: 97 min

Orbit cycle: 126 days

Revisit period: 5 days

Altitude: 618 km

Swath: 30 km

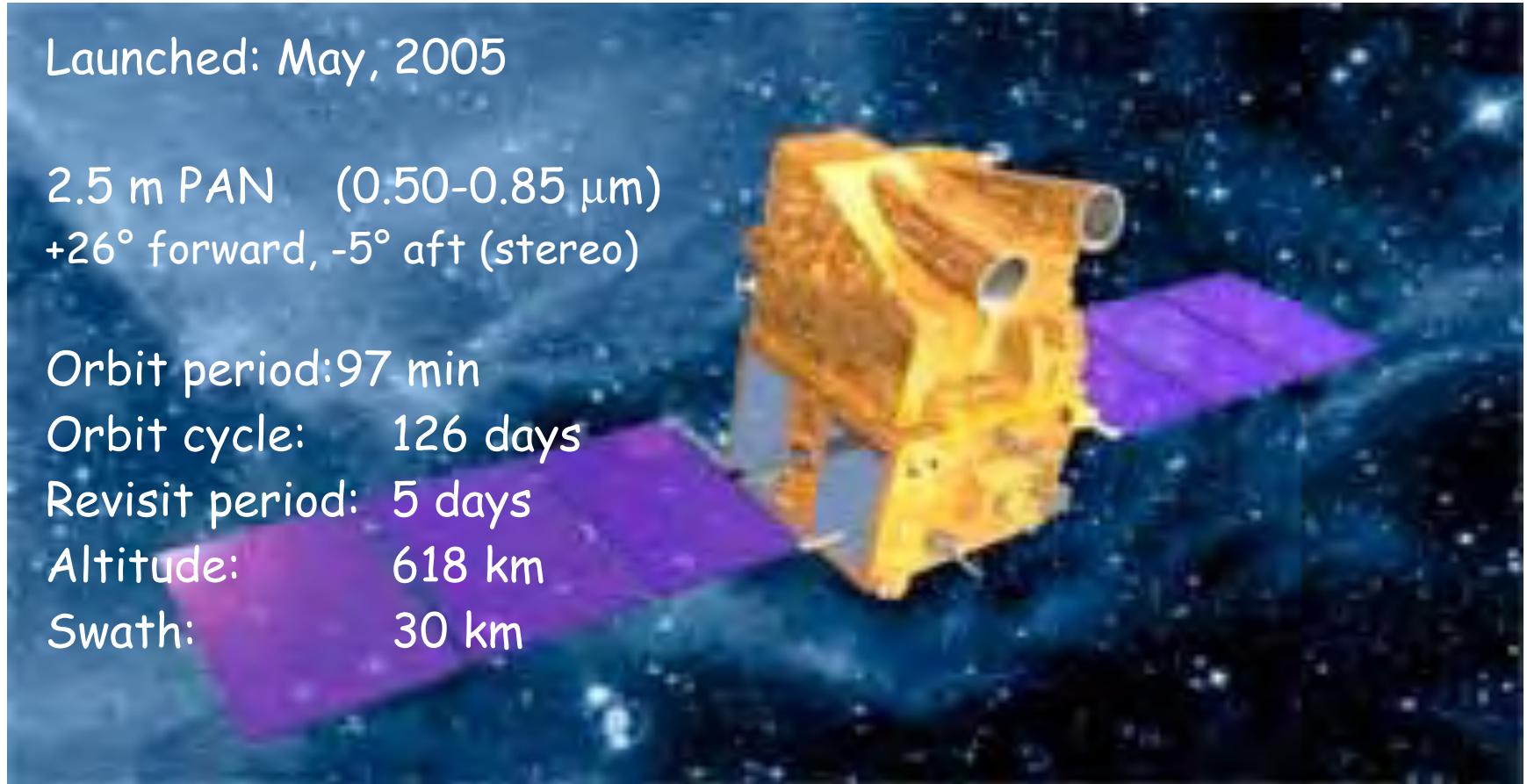

Jonas



1E1630
Remote Sensing
2005

Overview
Orbits
Satellites
Landsat
SPOT
Other ERS
Meteorological
Oceanic
Others

ERS (European Remote Sensing)

ERS-1 and ERS-2

This series of satellites were the first to be launched by the European Space Agency. They provide global and repetitive observations of the environment using advanced microwave techniques that enable imaging to take place regardless of cloud and sunlight conditions.

ERS-1 operated regularly from 25/7/1991 to 10/3/2000, ERS-2 started regular acquisitions in May 1995 and it is still fully operational.
Altitude: 785 km
Orbit period: 100 minutes
Revisit period 3-176 days

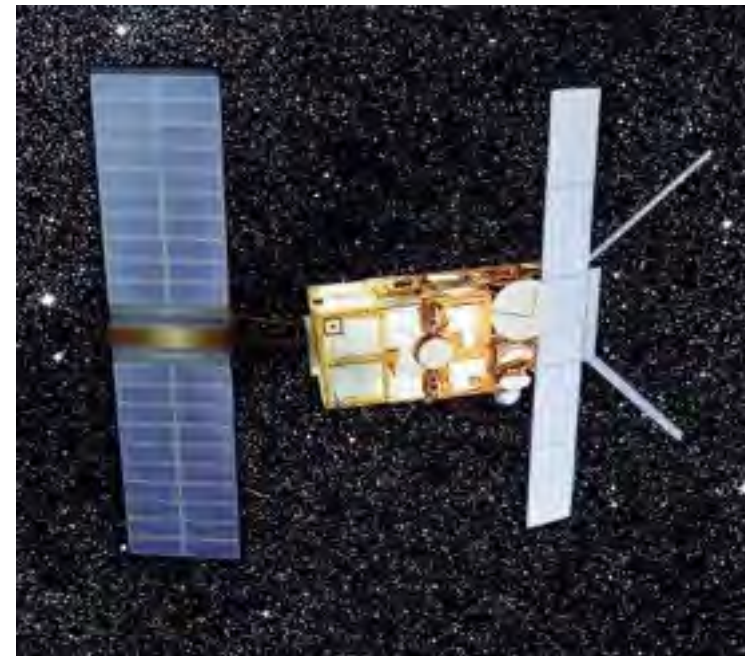

Jonas



1E1630
Remote Sensing
2005

Overview
Orbits
Satellites
Landsat
SPOT
Other ERS
Meteorological
Oceanic
Others

ERS Satellite Sensors

AMI - active microwave instrument consisting of a synthetic aperture radar (SAR) and a wind scatterometer (both C-band).
100 km swath, 30 m spatial resolution.

RA- radar altimeter: Nadir pointing pulse radar providing information on wave height, surface wind speed and sea-surface elevation. Also provides information on ice sheet topography.

ATSR - along-track scanning radiometer (operating in the infrared and visible ranges): measures sea surface temperatures, cloud top temperature and the vegetation cover of land surfaces.
500 km swath, 1000 m spatial resolution.

GOME - global ozone monitoring experiment, an absorption spectrometer which measures the presence of ozone, trace gases and aerosols in the stratosphere and troposphere.

MS - microwave sounder: supplies data on atmospheric humidity.

Jonas



1E1630
Remote Sensing
2005

Overview
Orbits
Satellites
Landsat
SPOT
Other ERS
Meteorological
Oceanic
Others

Other Earth Resource Satellites

RESURS

Russian satellites (visible, NIR and Thermal), with spatial resolution from 30 m. Forward conical scanning.

Swath 45-710 km.

ADEOS, JERS-1

Japanese satellites, with spatial resolutions from 8-16 m (ADEOS; visible-NIR) to 18 m (JERS; visible-MIR, Radar).

Swath 75-80 km.

CBERS

Chinese-Brazilian satellite with visible, IR and Thermal sensors.

Spatial resolution 20 - 260 m.

Swath 113-890 km.

EO, Earth Orbiter, with the 30 m hyperspectral sensor Hyperion (242 bands).

Jonas



1E1630
Remote Sensing
2005

Overview
Orbits
Satellites
Landsat
SPOT
Other ERS
Meteorological
Oceanic
Others

Meteorological Satellites

NOAA AVHRR Satellites (USA)

Orbit: Near-polar, sun-synchronous

AVHRR (Advanced Very High Resolution Radiometer)

Vegetation indices

Meteosat (Europe)

Orbit: Geostationary

GOES (USA)

Geostationary Operational Environmental Satellites)

Orbit: Geostationary

TIROS

POES

Jonas



1E1630
Remote Sensing
2005

Overview
Orbits
Satellites
Landsat
SPOT
Other ERS
Meteorological
Oceanic
Others

NOAA AVHRR Pass

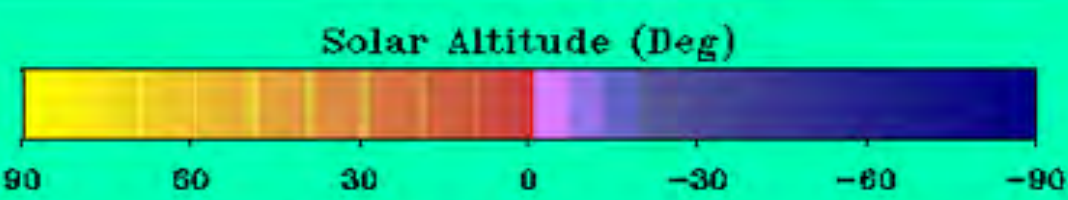
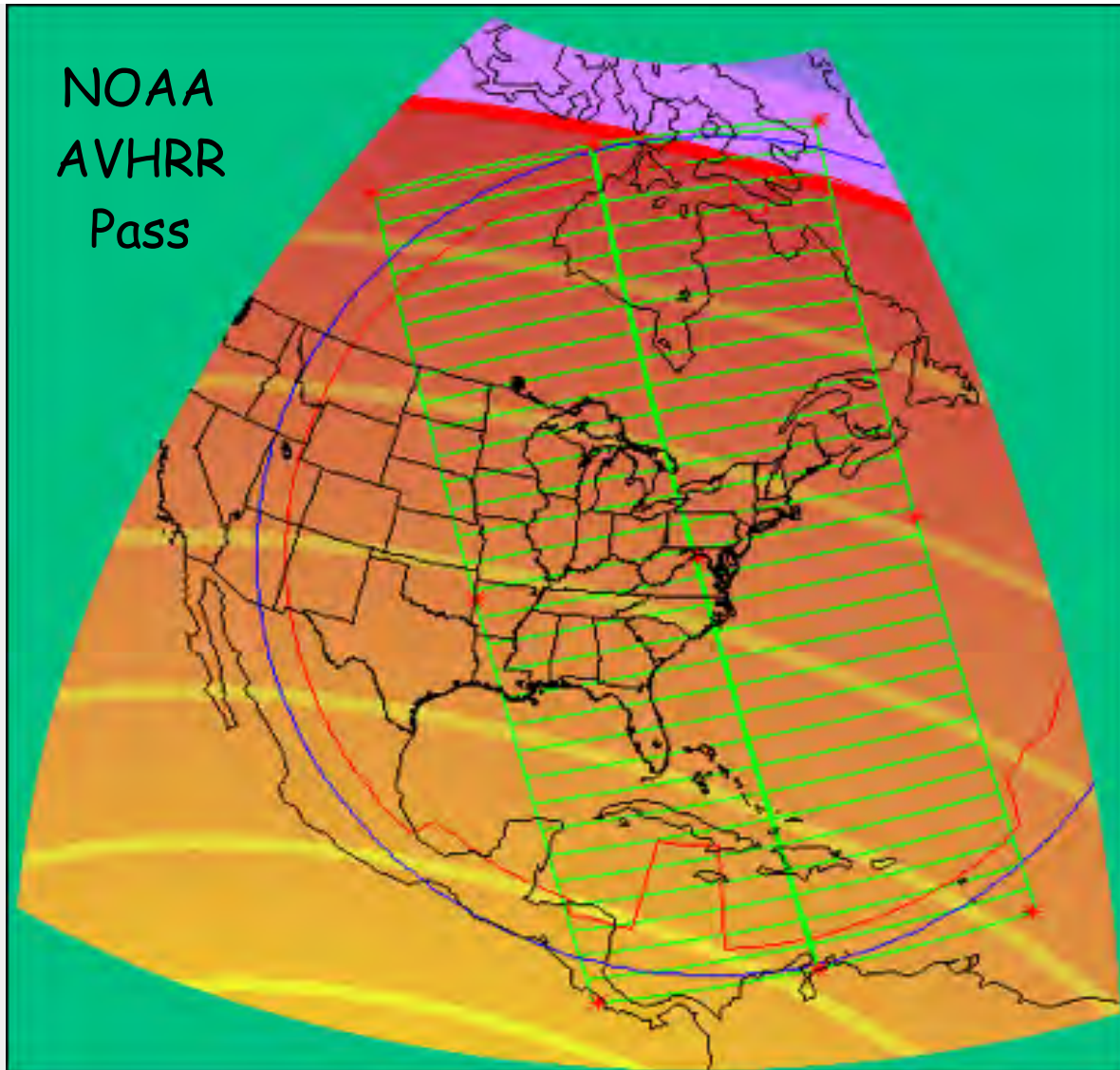

**NOAA-14 pass for
1995 Dec 26 18:24:43.14 UT**

Jonas



1E1630
Remote Sensing
2005

- Overview
- Orbits
- Satellites
- Landsat
- SPOT
- Other ERS
- Meteorological**
- Oceanic
- Others

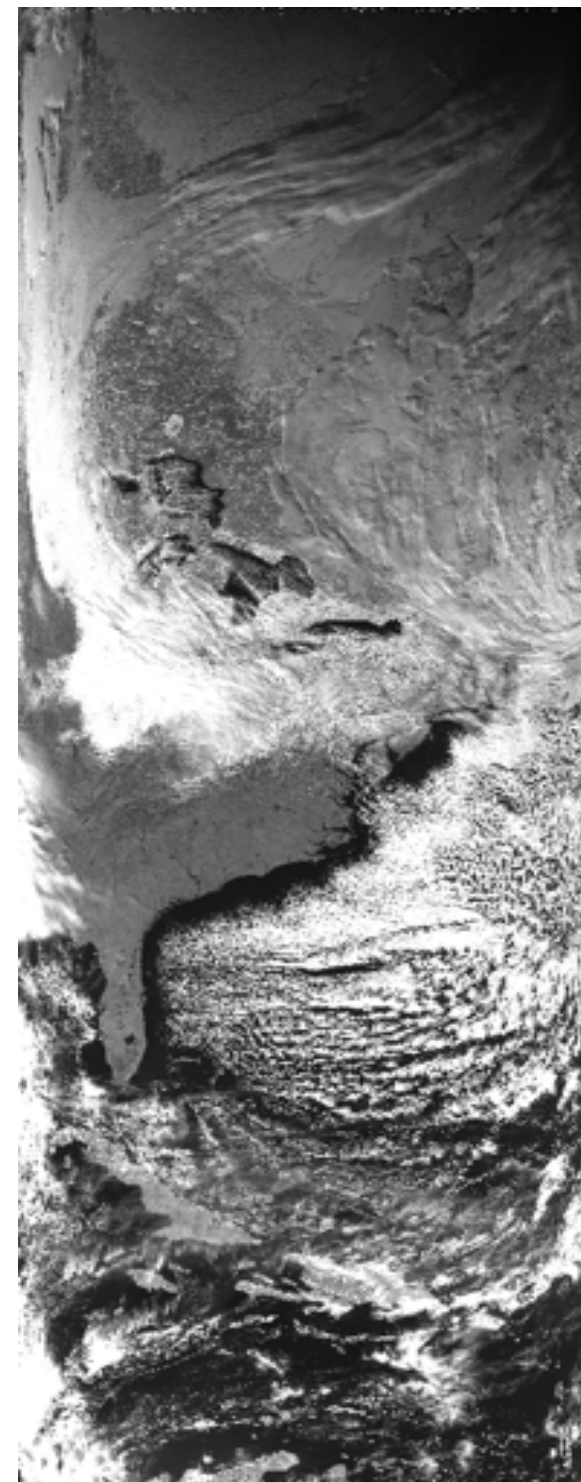

NASA / NOAA GOES Satellites

Frequent, small-scale imaging of the Earth's surface and cloud cover, used for weather monitoring for over 20 years.

Part of a global network of geostationary meteorological satellites.

15 minutes temporal resolution (between each image).

Detects radiation in 5 bands; the visible and 4 IR bands.

Spatial resolution: 1000 m (visible), 4000 m (IR)

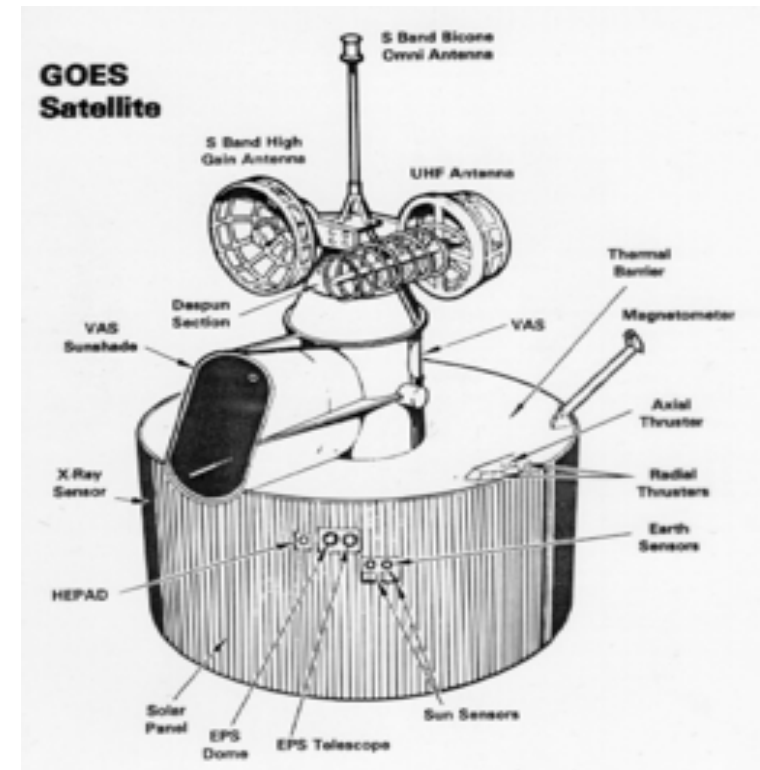

Jonas



1E1630
Remote Sensing
2005

Overview
Orbits
Satellites
Landsat
SPOT
Other ERS
Meteorological
Oceanic
Others

Meteorological Images

from geostationary satellite

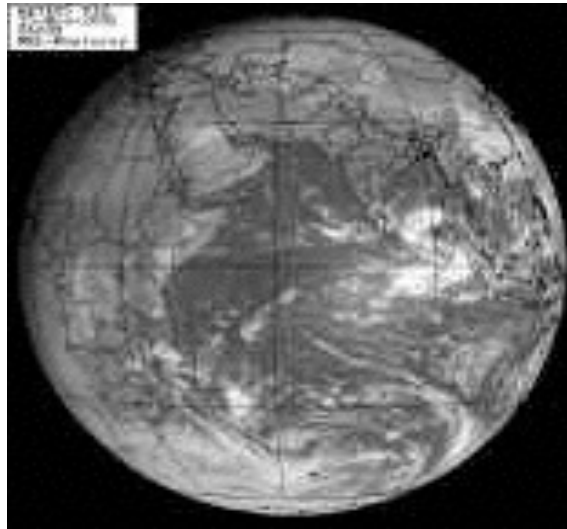

Visible

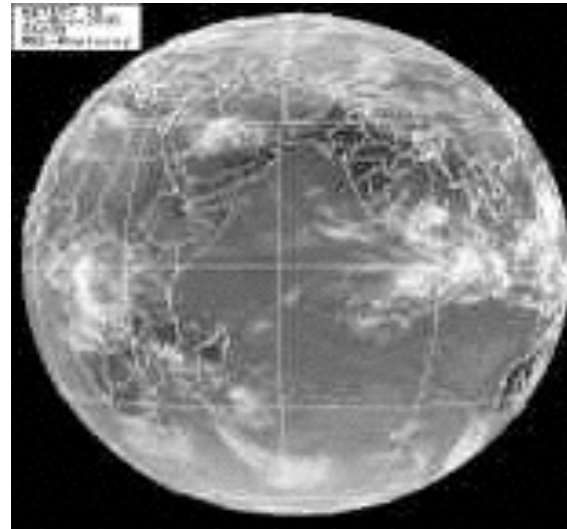

Infrared

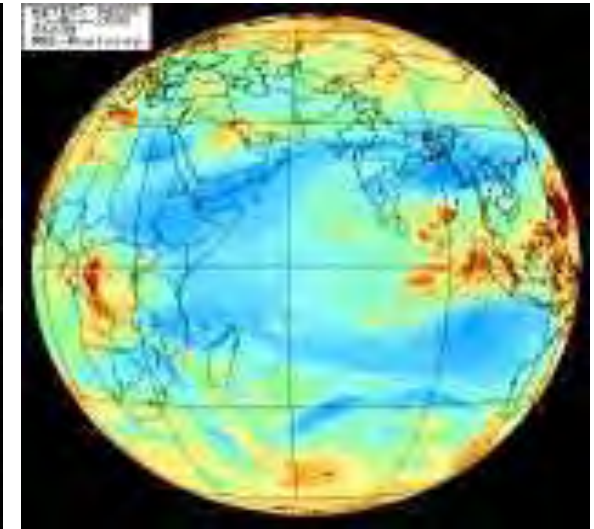

Water Vapor

Jonas



1E1630
Remote Sensing
2005

Overview
Orbits
Satellites
Landsat
SPOT
Other ERS
Meteorological
Oceanic
Others

NOAA – AVHRR data

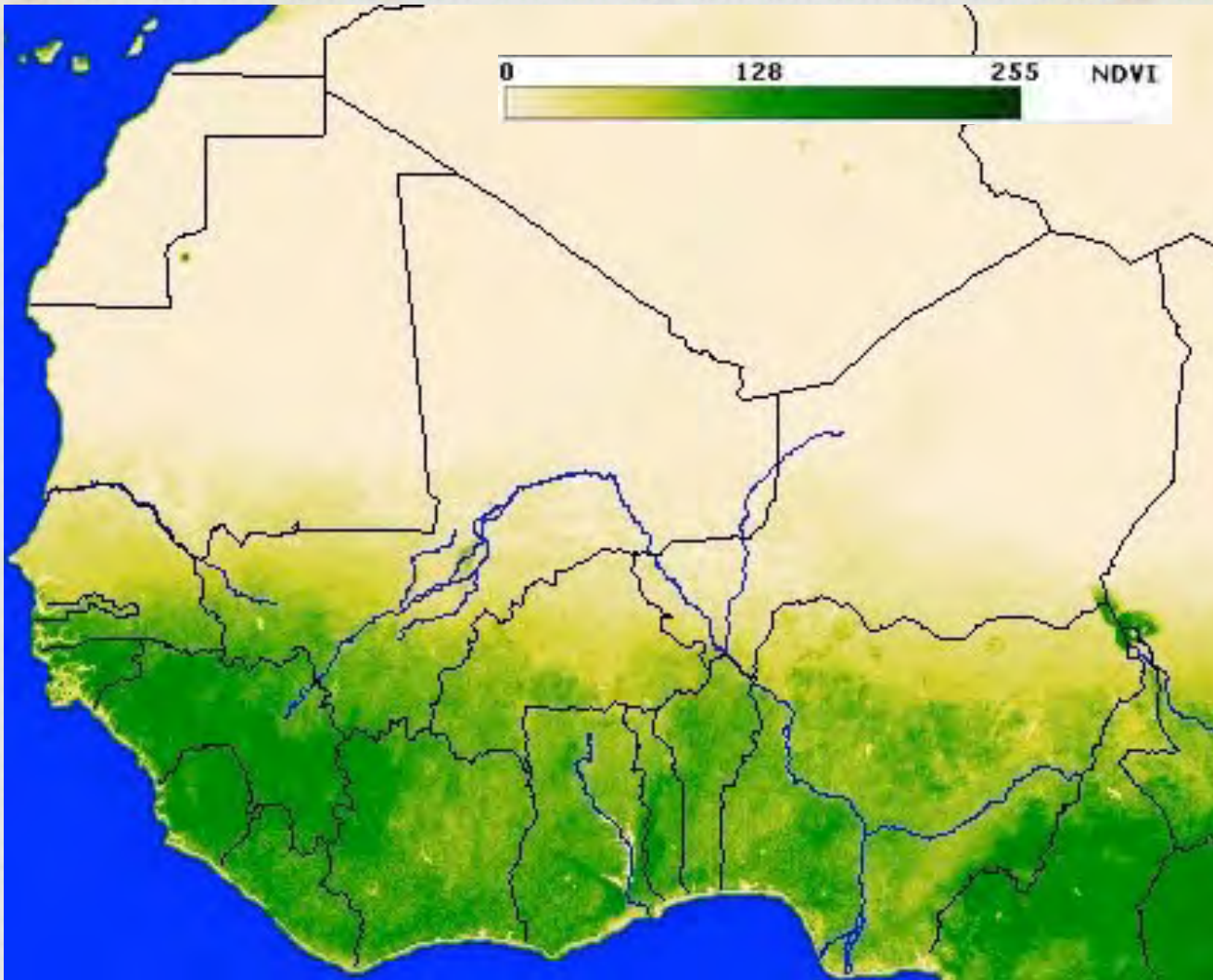

The longest consistent time series of satellite derived NDVI available is from the Advanced Very High Resolution Radiometer (AVHRR) instruments operated by the National Oceanic and Atmospheric Administration (NOAA) in the United States of America.

The data used here is derived from 5 generations of AVHRR sensors, carried onboard NOAA -7, -9, -11, -14 and -16.

Sahel rainfall average 1982-2004

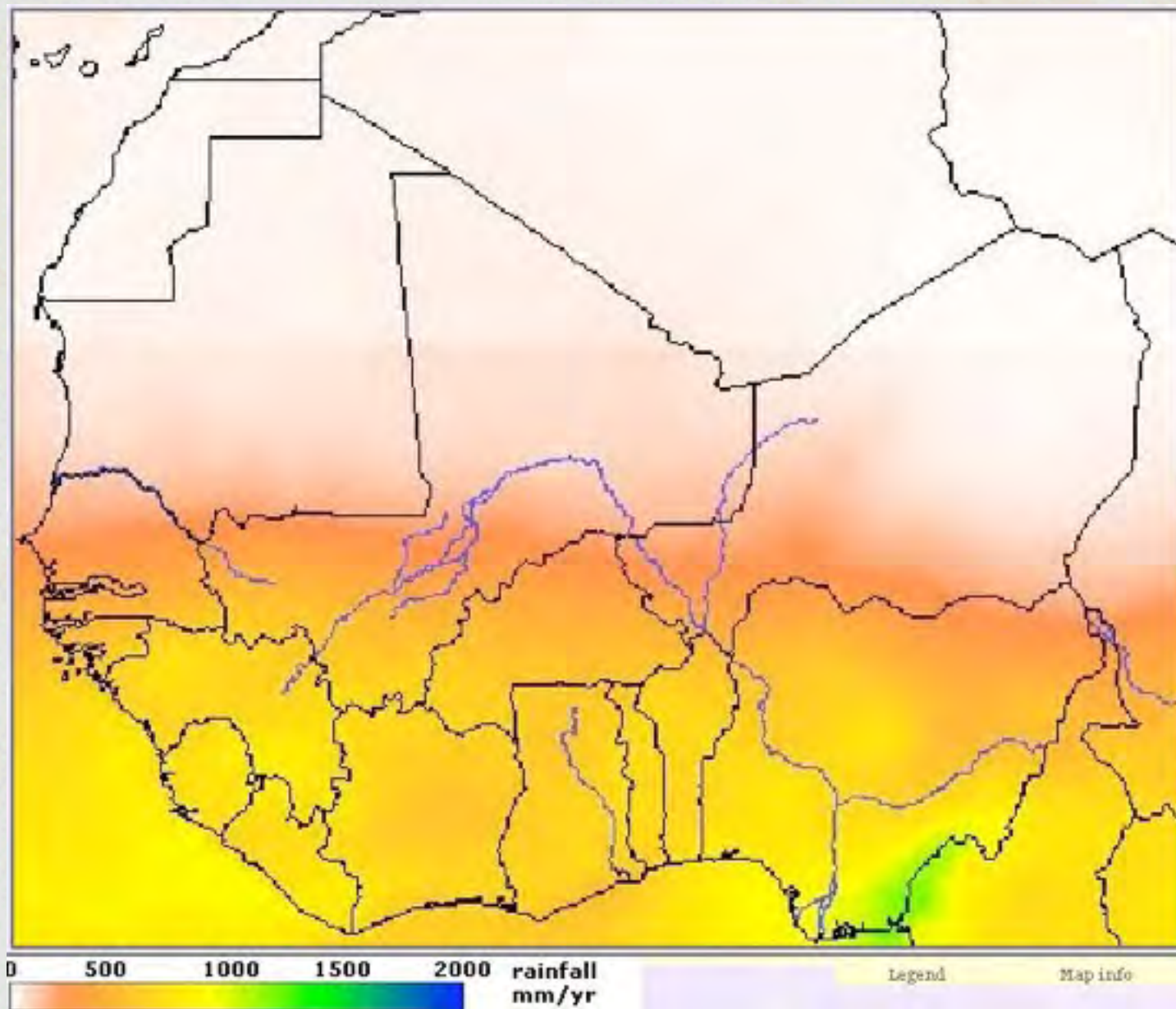

Oceanographical Satellites

SeaSat (1978)

Nimbus-7 with the **CZCS** (Coastal Zone Colour Scanner)
(1978-1986)

OrbView-2 satellite with the **SeaWiFS** (Sea-viewing Wide Field-of-view Sensor)

The Japanese **MOS** (Marine Observation Satellite)

ESA's **Envisat** with the **MERIS** (Medium Resolution Imaging Spectrometer)

Russia's **OKEAN**

Jonas



1E1630
Remote Sensing
2005

Overview
Orbits
Satellites
Landsat
SPOT
Other ERS
Meteorological
Oceanic
Others

CZCS

The Nimbus-7 satellite carried the Coastal Zone Colour Scanner (**CZCS**), for detecting phytoplankton, suspended solids, and temperature. It was in operation from 1978-1986.

Orbit: Near-polar
Altitude: 800 km
Spatial resolution: 825 m
Swath width: 1566 km

Channel	Band (μm)	Application
1	0.43-0.45	Chlorophyll absorption
2	0.51-0.53	Chlorophyll absorption
3	0.54-0.56	Gelbstoffe (yellow substance)
4	0.66-0.68	Chlorophyll concentration
5	0.70-0.80	Surface vegetation
6	10.5-12.5	Surface temperature

Jonas



1E1630
Remote Sensing
2005

Overview
Orbits
Satellites
Landsat
SPOT
Other ERS
Meteorological
Oceanic
Others

SeaWiFS Chlorophyll Image

Jonas



1E1630
Remote Sensing
2005

Overview
Orbits
Satellites
Landsat
SPOT
Other ERS
Meteorological
Oceanic
Others

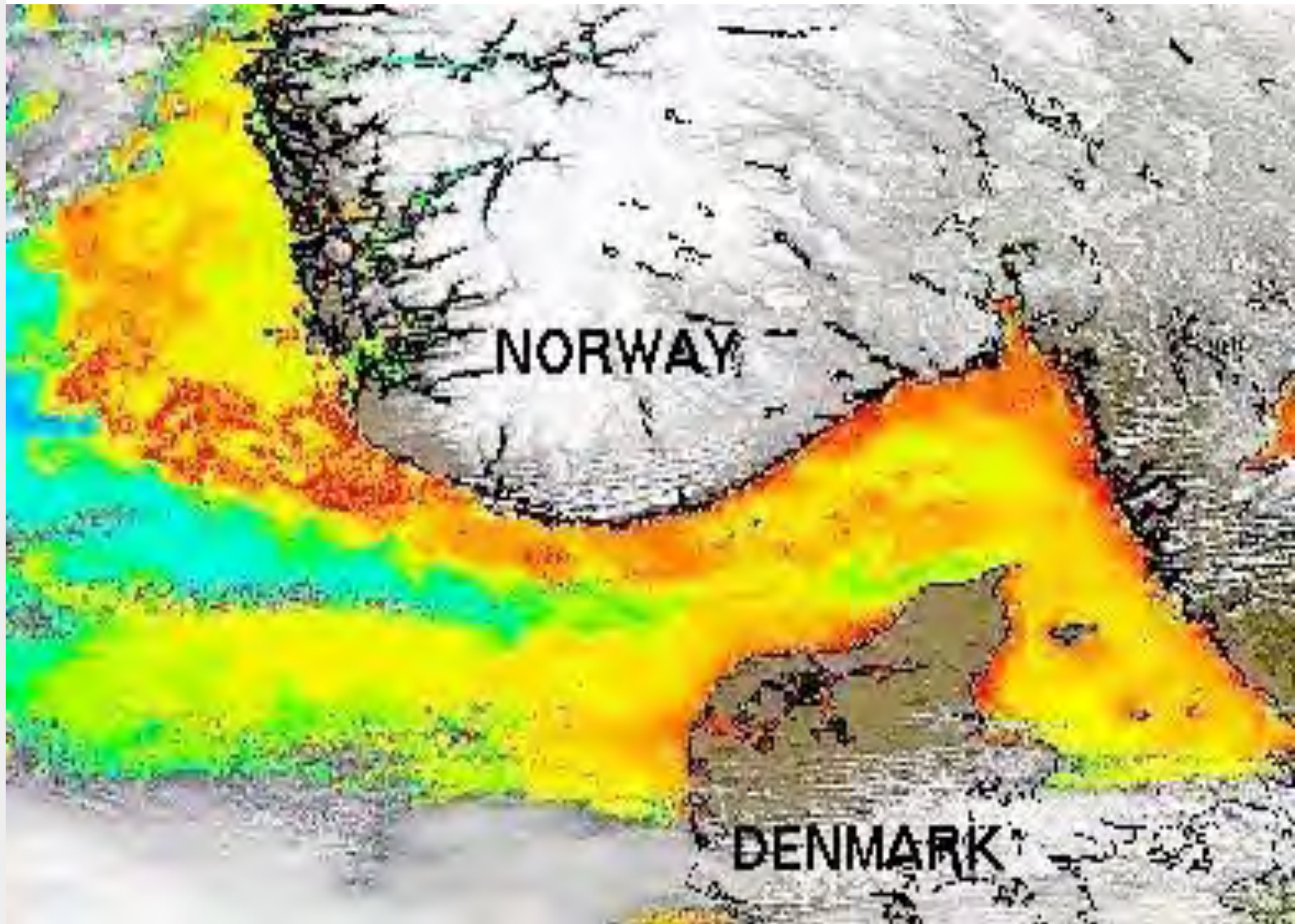

EOS (Earth Observing System)

EOS is one of the primary components of NASA's "Mission to Planet Earth" (MTPE) concept, later renamed to Earth Science Enterprise (ESE).

It is an international earth science program, and includes numerous platforms covering such wide aspects as land, ocean, weather and the environment as a whole.

In this overview, two satellite platforms can be mentioned, **Terra** (1999) and **Aqua** (2002). Both of these satellites carry multiple remote sensing instruments.

The intent is to provide a suite of synergistic instruments on each platform, to complement and correct each other.

Both are in 705 km sun-synchronous orbits.

Jonas



1E1630
Remote Sensing
2005

Overview
Orbits
Satellites
Landsat
SPOT
Other ERS
Meteorological
Oceanic
Others

EOS Terra Sensors

Sensor	General info	Applications
ASTER	Three scanners (visible, IR, Thermal IR), along-track stereo, 15-90 m resolution	Vegetation, DEMs, rock types, clouds
MISR	Four-channel CCD arrays, 9 possible angles	Multi-angle views
MOPITT	Three-channel Near-IR scanner	Measure carbon monoxide and methane in the atmosphere
CERES	Two broadband scanners	Earth's total radiation energy balance
MODIS	36-channel imaging spectrometer, 250-1000 m resolution	Clouds, multiple land- and ocean applications

Jonas



1E1630
Remote Sensing
2005

Overview
Orbits
Satellites
Landsat
SPOT
Other ERS
Meteorological
Oceanic
Others

EOS Aqua Sensors

Sensor	General info	Applications
CERES	Two broadband scanners	Earth's total radiation energy balance
MODIS	36-channel imaging spectrometer, 250-1000 m resolution	Clouds, multiple land- and ocean applications
AIRS	Hyperspectral sensor with 2378 channels, 2-14 km resolution	Atmospheric temperature and humidity
AMSR/E	12-channel microwave radiometer	Precipitation, wetness, snow cover, sea surface
AMSU	15-channel microwave radiometer	Atmospheric temperature and humidity
HSB	5-channel microwave radiometer	Atmospheric humidity

Jonas



1E1630
Remote Sensing
2005

Overview
Orbits
Satellites
Landsat
SPOT
Other ERS
Meteorological
Oceanic
Others

IKONOS

Launched: Sep 24, 1999

1 m PAN	(0.45-0.90)
4 m MS	(0.45-0.52)
	(0.52-0.60)
	(0.63-0.69)
	(0.76-0.90)

Radiometric: 11 bit

Altitude: 681 km

Swath: 11 km

Off-nadir: +/- 45°

(all directions)

IKONOS is made to be highly manouverable, to quickly change its pointing on-the-fly, to follow winding features.



San Francisco (IKONOS image)

Jonas



1E1630
Remote Sensing
2005

Overview
Orbits
Satellites
Landsat
SPOT
Other ERS
Meteorological
Oceanic
Others

Quickbird

Launched: Oct 18, 2001

0.61 m PAN (0.45-0.90)
2.40 m MS (0.45-0.52)
(0.52-0.60)
(0.63-0.69)
(0.76-0.90)

Radiometric: 11 bit
Altitude: 450 km
Swath: 16.5 km
Off-nadir: +/- 45°



Jonas



1E1630
Remote Sensing
2005

Overview
Orbits
Satellites
Landsat
SPOT
Other ERS
Meteorological
Oceanic
Others

Currently the highest resolution satellite imagery available to the public.

Skanning och digitalisering

Digitaliseringsbord

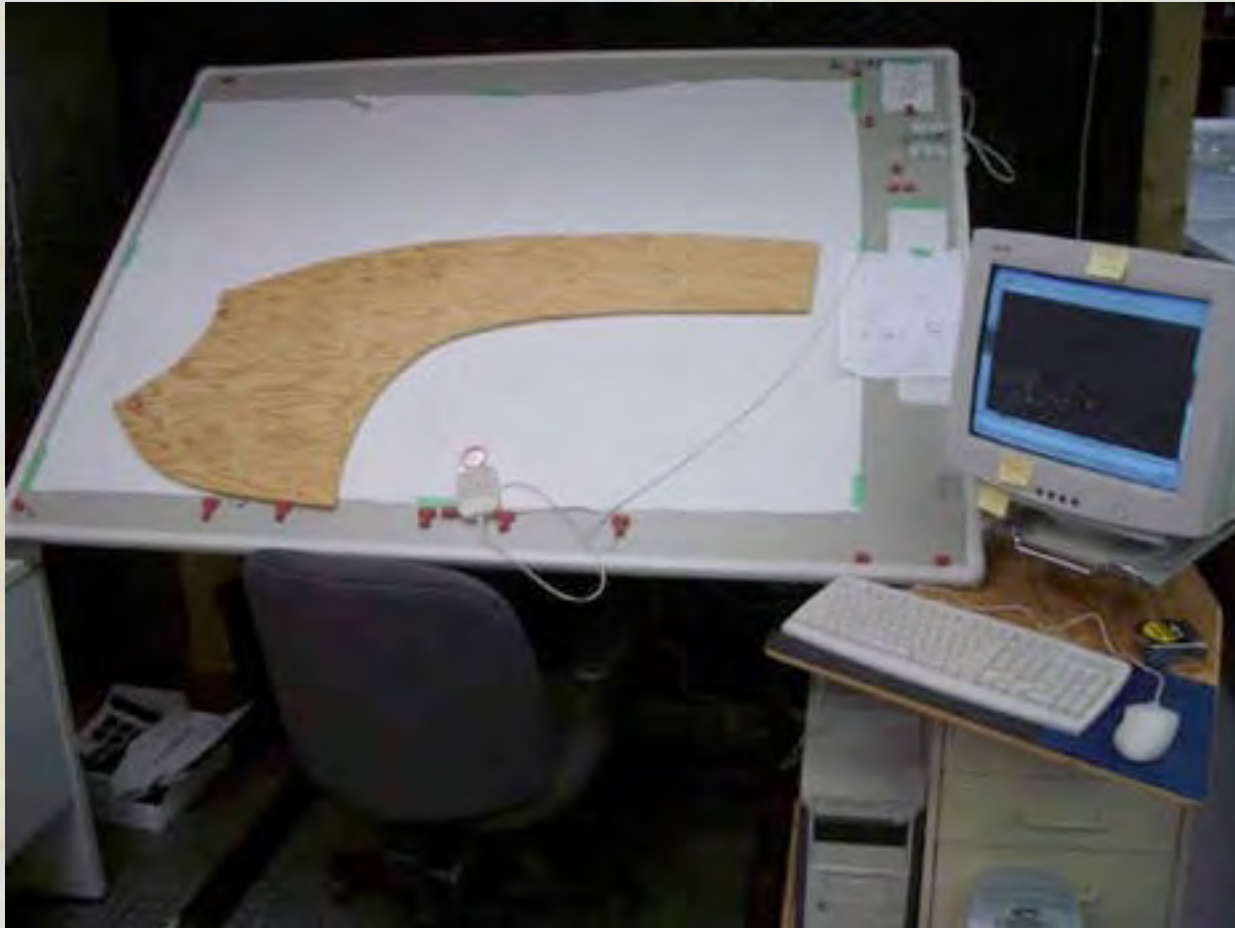

Skanning och digitalisering

Digitalisering

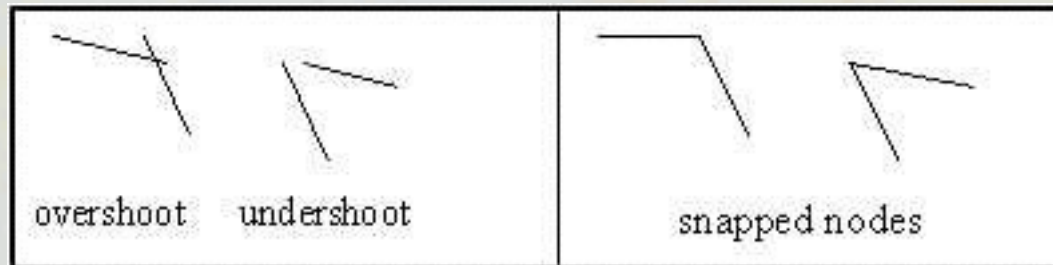

Skanning och digitalisering

Fatbäddsskanner



Trumskanner



Skanning och digitalisering



Kontrollpunkter för att rektifiera flygfoto/satellitbild till ortokarta

Kvalitet och metadata

- Kvalitetsmärkning av geografiska data:
 - Produktionsmetod
 - Produktionsdatum
 - Lägesnoggrannhet
 - Tematisk noggrannhet
 - Attributnoggrannhet
 - Logisk konsistens
 - Fullständighet
 - Aktualitet